

HSP 300 2trg MM

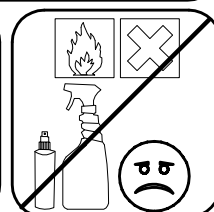
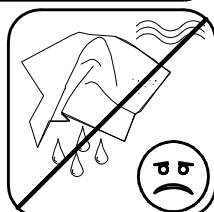
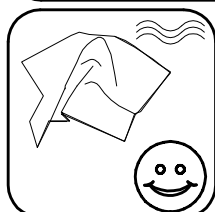
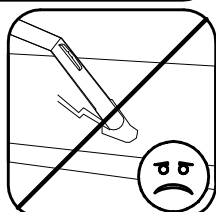
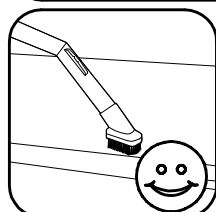
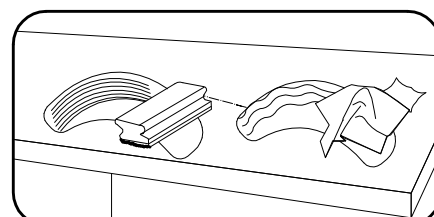
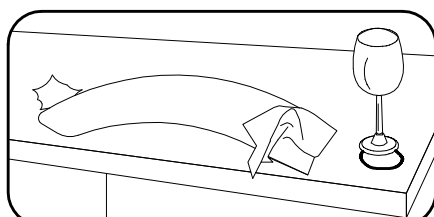
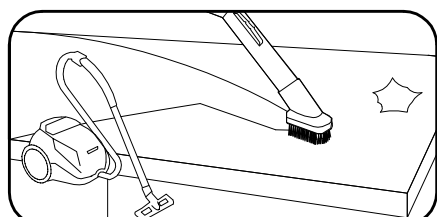
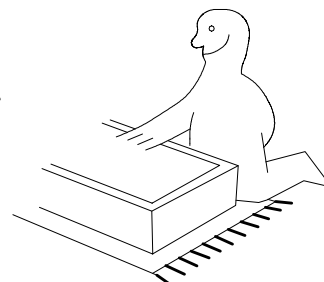
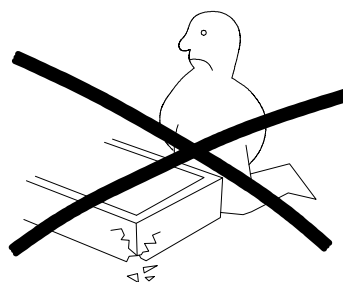
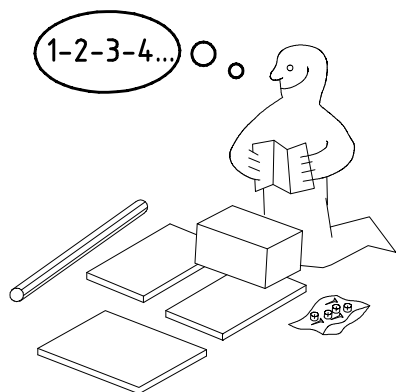
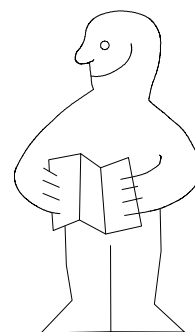
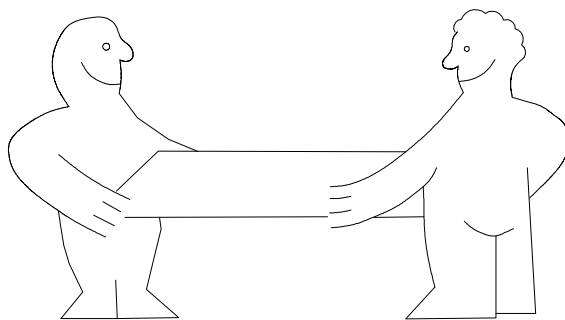
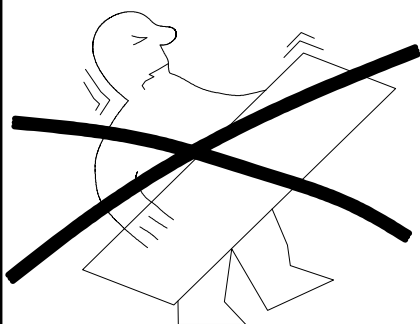

**⚠ DEU - deutsch WARNUNG - SICHERHEITSHINWEIS**

**Nicht fachgerecht montierte oder nicht bestimmungsgemäß genutzte Möbel können lebensgefährlich sein. Daher sind folgende Sicherheitshinweise unbedingt zu beachten:**

- Die Montage der Möbel ist durch fachkundiges Personal anhand der Montageanleitung durchzuführen. Schrauben dürfen nicht überdreht werden. Kinder sind bei der Montage fernzuhalten.
- Alle Pakete sind zu öffnen und alle Montageanleitungen und Sicherheitshinweise zu lesen. Diese Dokumente sind aufzubewahren. Für die Montage sind nur Originalteile zulässig.
- Möbel mit beigelegter Wandbefestigung sind zwingend an der Wand zu befestigen. Dabei ist der beigelegte Sicherheitshinweis zur Wandbefestigung zu beachten.
- Möbel bergen Gefahren für Kinder: Achten Sie daher darauf, dass Kinder nicht in Schubladen oder auf andere Teile klettern oder sich daran hochziehen oder hängen.
- Die Möbel sind für folgende maximale Belastungen geeignet: Betten (pro Liegefläche): 100kg, Ankleidebänke: 110kg, Nachtschrank- und Kommodenplatten: 15kg, Paneel-Glasböden: 1kg, Wandoberflächen: bauartabhängig, Schubkästen: 5kg, Einlegeböden: 10kg, Kleiderstangen: 40kg, Hängeschränke: 20kg, Kleiderlitt: 10kg, Bettschubkästen: 10kg.

**⚠ ENG - english WARNING - SAFETY INSTRUCTIONS**

**Furniture that is not assembled correctly or not used as intended can be life-threatening. To avoid this danger and reduce the risk of injury, the following safety instructions must be observed:**

- The furniture must be assembled by qualified personnel in accordance with the assembly instructions. Screws must not be overtightened. Keep children away during assembly.
- All packages must be opened and all assembly instructions and safety instructions must be read. These documents must be kept in a safe place. Only original parts may be used for assembly.
- Furniture with enclosed wall mounting must be fixed to the wall. The enclosed safety instructions for wall mounting must be observed.
- Furniture harbours dangers for children: Therefore, make sure that children do not climb into drawers or onto other parts or pull themselves up or hang from them.
- The furniture is suitable for the following maximum loads: Beds (per mattress base): 100kg, dresser benches: 110kg, bedside cabinet and chest of drawers tops: 15kg, panel glass shelves: 1kg, wall boards: depending on type, drawers: 5kg, fitted shelves: 10kg, clothes rails: 40kg, wall units: 20kg, clothes lift: 10kg, bed drawers: 10kg.

**⚠ ESP - español ADVERTENCIA - INSTRUCCIONES DE SEGURIDAD**

**Los muebles que no se monten correctamente o no se utilicen conforme a lo previsto pueden poner en peligro la vida de las personas. Por lo tanto, se deben observar las siguientes instrucciones de seguridad:**

- El mobiliario debe ser montado por personal cualificado de acuerdo con las instrucciones de montaje. Los tornillos no deben apretarse en exceso. Mantenga a los niños alejados durante el montaje.
- Deben abrirse todos los embalajes y leerse todas las instrucciones de montaje y de seguridad. Estos documentos deben guardarse en un lugar seguro. Para el montaje sólo deben utilizarse piezas originales.
- Los muebles con fijaciones murales adjuntas deben fijarse a la pared. Deben observarse las instrucciones de seguridad adjuntas para el montaje mural.
- Los muebles encierran peligros para los niños: por eso, asegúrese de que los niños no se suban a los cajones o a otras partes, ni se tiren o cuelguen de ellos.
- Los muebles son adecuados para las siguientes cargas máximas: Camas (por somier): 100kg, Tocadores: 110kg, Tableros de mesillas y cajoneras: 15kg, Estantes de cristal: 1kg, Estantes de pared: según el tipo, cajones: 5 kg, estantes empotrados: 10 kg, barras de colgar: 40 kg, armarios altos: 20 kg, elevador de ropa: 10 kg, cajones de cama: 10 kg.

**⚠ NED - nederlands WAARSCHUWING - VEILIGHEIDINSTRUCTIES**

**Meubels die niet correct gemonteerd zijn of niet gebruikt worden zoals bedoeld, kunnen levensgevaarlijk zijn. Daarom moeten de volgende veiligheidsinstructies in acht worden genomen:**

- De meubels moeten door gekwalificeerd personeel worden geassembleerd volgens de montagehandleiding. Schroeven mogen niet te vast worden aangedraaid. Houd kinderen tijdens de montage uit de buurt.
- Alle verpakkingen moeten worden geopend en alle montage- en veiligheidsinstructies moeten worden gelezen. Deze documenten moeten goed worden bewaard. Voor de montage mogen alleen originele onderdelen worden gebruikt.
- Meubels met beigeleverde wandbevestigingen moeten aan de muur worden bevestigd. De bijgevoegde veiligheidsinstructies voor wandmontage moeten in acht worden genomen.
- Meubels houden gevaar in voor kinderen: zorg eraan op te passen dat kinderen niet in lades of op andere onderdelen klimmen, zich eraan optrekken of eraan hangen.
- De meubels zijn geschikt voor de volgende maximale belastingen: Bedden (per matrasbodem): 100kg, commodebanken: 110kg, nachtkastje en commodebladen: 15kg, glazen legplanken: 1kg, wandplanken: afhankelijk van type, laden: 5kg, legplanken: 10kg, kledingstangen: 40kg, hangelementen: 20kg, kledinglitt: 10kg, bedladen: 10kg.

**⚠ FRA - français AVERTISSEMENT - CONSIGNE DE SÉCURITÉ**

**Les meubles qui ne sont pas montés dans les règles de l'art ou qui ne sont pas utilisés conformément à leur destination peuvent présenter un danger de mort. Par conséquent, les consignes de sécurité suivantes doivent être respectées :**

- Le montage des meubles doit être effectué par un personnel compétent à l'aide des instructions de montage. Les vis ne doivent pas être trop serrées. Éloignez les enfants pendant le montage.
- Tous les paquets doivent être ouverts et toutes les instructions de montage et les consignes de sécurité doivent être lues. Ces documents doivent être conservés. Seules les pièces d'origine sont autorisées pour le montage.
- Les meubles avec fixation murale jointe doivent impérativement être fixés au mur. Ce faisant, il convient de respecter la consigne de sécurité jointe relative à la fixation murale.
- Les meubles présentent des dangers pour les enfants : veillez donc à ce que les enfants ne grimpent pas dans les tiroirs ou sur d'autres éléments, ne s'y hissent pas et ne s'y pendent pas.
- Les meubles sont adaptés aux charges maximales suivantes : Lits (par surface de couchage) : 100kg, bancs de dressing : 110kg, panneaux de chevet et commodes : 15kg, étagères en verre de panneaux : 1kg, tableaux muraux : en fonction du type de construction, tiroirs : 5kg, étagères : 10kg, barres de penderie : 40kg, armoires suspendues : 20kg, ascenseur à vêtements : 10kg, tiroirs de lit : 10kg.

**⚠ ITA - Italiano AVVERTIMENTO - ISTRUZIONI DI SICUREZZA**

**I mobili non montati correttamente o non utilizzati come previsto possono essere pericolosi per la vita. Per evitare questo pericolo e ridurre il rischio di lesioni, è necessario osservare le seguenti istruzioni di sicurezza:**

- I mobili devono essere assemblati da personale qualificato secondo le istruzioni di montaggio. Le viti non devono essere serrate eccessivamente. Tenere lontani i bambini durante il montaggio.
- Tutte le confezioni devono essere aperte e tutte le istruzioni di montaggio e di sicurezza devono essere lette. Questi documenti devono essere conservati in un luogo sicuro. Per il montaggio devono essere utilizzati solo pezzi originali.
- I mobili con montaggio a parete devono essere fissati alla parete. Osservare le istruzioni di sicurezza allegate per il montaggio a parete.
- I mobili nascondono pericoli per i bambini: Pertanto, assicuratevi che i bambini non si arrampichino sui cassetti o su altre parti, né si tirino su o si appendano ad essi.
- I mobili sono adatti ai seguenti carichi massimi: Letti (per rete): 100 kg, panche per comò: 110 kg, piani di comodini e cassettiere: 15 kg, ripiani in vetro: 1 kg, pannelli a muro: a seconda del tipo, cassetti: 5 kg, mensole a muro: 10 kg, appendiabiti: 40 kg, pensili: 20 kg, alzabiti: 10 kg, cassetti del letto: 10 kg.

**⚠ POL - polski OSTRZEŻENIE - INSTRUKCJE BEZPIECZEŃSTWA**

**Nieprawidłowo zmontowane lub użytkowane niezgodnie z przeznaczeniem meble mogą stanowić zagrożenie dla życia. Dlatego należy przestrzegać następujących instrukcji bezpieczeństwa:**

- Meble muszą być montowane przez wykwalifikowany personel zgodnie z instrukcją montażu. Śrub nie wolno dokręcać zbyt mocno. Trzymaj dzieci z daleka podczas montażu.
- Należy otworzyć wszystkie opakowania i przeczytać wszystkie instrukcje montażu i instrukcje bezpieczeństwa. Dokumenty te należy przechowywać w bezpiecznym miejscu. Do montażu można używać wyłącznie oryginalnych części.
- Meble z dołączonymi mocowaniami ściennymi muszą być przymocowane do ściany. Należy przestrzegać załączonych instrukcji bezpieczeństwa dotyczących montażu na ścianie.
- Meble są niebezpieczne dla dzieci: dlatego należy upewnić się, że dzieci nie wspinają się do szuflad lub na inne części, nie podciągają się ani nie wiszą z nich.
- Meble są przystosowane do następujących maksymalnych obciążeń: Łóżka (za podstawę materaca): 100kg, ławy komody: 110kg, blaty szafek nocnych i komód: 15kg, półki szklane panele: 1kg, płyty ścienne: w zależności od typu, szuflady: 5kg, półki dopasowane: 10kg, drążki na ubrania: 40kg, szafki wiszące: 20kg, podnośnik do ubrań: 10kg, szuflady łóżek: 10kg.

**⚠ POR - portuguese AVISO - INSTRUÇÕES DE SEGURANÇA**

**A montagem incorrecta ou a utilização incorrecta de um móvel pode pôr em risco a sua vida. Por conseguinte, é essencial respeitar as seguintes instruções de segurança:**

- A montagem dos móveis deve ser efectuada por pessoal qualificado e de acordo com as instruções de montagem. Os parafusos não devem ser demasiado apertados. As crianças devem ser mantidas afastadas durante a montagem.
- Todas as embalagens devem ser abertas e todas as instruções de montagem e de segurança devem ser lidas. Estes documentos devem ser guardados num local seguro. Para a montagem, só podem ser utilizadas peças originais.
- Os móveis com fixações de parede incluídas devem ser fixados à parede. As instruções de segurança anexas para a montagem na parede devem ser respeitadas.
- Os móveis comportam perigos para as crianças: por isso, certifique-se de que as crianças não sobem para as gavetas ou para outras peças, nem se puxam para cima ou se penduram nelas.
- Os móveis são adequados para as seguintes cargas máximas: Camas (por base de colchão): 100 kg, bancos de vestir: 110 kg, tampos de armários de cabeceira e de cómodas: 15 kg, prateleiras de vidro: 1 kg, Prateleiras de parede: 7,5 kg consoante o tipo, gavetas: 5 kg, prateleiras embutidas: 10 kg, varões para roupa: 40 kg, móveis de parede: 20 kg, elevador de roupa: 10 kg, gavetas de cama: 10 kg.

**⚠ SVN - slovensko OPOZORILO - VARNOSTNA OPOMBA**

**Pohištvo, ki ni pravilno sestavljeno ali se ne uporablja, kot je predvideno, lahko ogrozi življenje. Da bi se izognili tej nevarnosti in zmanjšali tveganje poškodb, je treba upoštevati naslednja varnostna navodila:**

- Pohištvo mora sestaviti uposobljeno osebo po navodilih za sestavljanje. Vijaki ne smejo biti preveč zategnjeni. Med sestavljanjem se morajo otroci izogibati.
- Vse pakete je treba odpreti in prebrati vsa navodila za montažo in varnostna navodila. Te dokumente je treba hraniti na varnem mestu. Za sestavljanje se lahko uporabljajo samo originalni deli.
- Pohištvo s priloženimi stenskim pritrilji je treba pritriliti na steno. Upoštevati je treba priložena varnostna navodila za pritriljev na steno.
- Pohištvo skriva nevarnosti za otroke: zato poskrbite, da otroci ne bodo plezali v predale ali na druge dele, se dvigovali ali obešali z njih.
- Pohištvo je primerno za naslednje največje obremenitve: (na vzmetnico): Vgradni predali: 100 kg, komoda: 110 kg, vrhovi nočnih omarič in komod: 15 kg, steklene police: 1 kg, stenske plošče: odvisno od vrste, predali: 5 kg, vgradne police: 10 kg, vodila za oblačila: 40 kg, stenske enote: 20 kg, dvigalo za oblačila: 10 kg, posteljni predali: 10 kg.

**⚠ CZE - český VAROVÁNÍ - BEZPEČNOSTNÍ UPOZORNĚNÍ**

**Nábytek, který není správně sestaven nebo není používán v souladu se svým určením, může být životu nebezpečný. Abyste tomuto nebezpečí předešli a snížili riziko zranění, je nezbytné dodržovat následující bezpečnostní pokyny:**

- Montáž nábytku musí provádět kvalifikovaný personál podle montážního návodu. Šrouby nesmí být příliš utahovány. Děti musí být během montáže drženy mimo dosah.
- Všechna balení musí být otevřena a musí být přečteny všechny montážní a bezpečnostní pokyny. Tyto dokumenty musí být uloženy na bezpečném místě. K montáži se smí používat pouze originální díly.
- Nábytek s přiloženými nástennými úchyty musí být připevněn ke stěně. Je třeba dodržovat přiložené bezpečnostní pokyny pro montáž na stěnu.
- Nábytek skrývá nebezpečí pro děti: Dbejte proto na to, aby děti nelezly do zásuvek nebo na jiné části, nevytahovali se na ně nebo z nich nevisely.
- Nábytek je vhodný pro následující maximální zatížení: (na podklad matrace): (na matraci): 100 kg, lavičky komody: 110 kg, desky nočních stolků a komody: 15 kg, skleněné police: 1 kg, nástěnné desky: podle typu, zásuvky: 5 kg, vstavané police: 10 kg, věšáky na oblečení: 40 kg, nástěnné skříně: 20 kg, zvedák na oběd: 10 kg, zásuvky postele: 10 kg.

**⚠ HUN - magyar FIGYELMEZTETÉS - BIZTONSÁGI MEGJEGYZÉS**

**A nem megfelelően összeszerelt vagy nem rendeltetészerűen használt bútork életveszélyesek lehetnek. Ezért a következő biztonsági utasításokat kell betartani:**

- A bútorkat szakképzett személyzetnek kell összeszerelnie az összeszerelési útmutató alapján. A csavarokat nem szabad túlhúzni. Az összeszerelés során a gyerekeket távol kell tartani.
- Minden csomagot fel kell bontani, és el kell olvasni az összes összeszerelési útmutatót és biztonsági utasítást. Ezeket a dokumentumokat biztonságos helyen kell tárolni. Az összeszereléshez csak eredeti alkatrészeket szabad felhasználni.
- A mellékelt falkarokkal ellátott bútorkat a falhoz kell rögzíteni. A mellékelt, falra szerelésre vonatkozó biztonsági utasításokat be kell tartani.
- A bútork veszélyeket rejtnek a gyermekek számára: Ezért ügyeljen arra, hogy a gyermekek ne másszanak be a fiókokba vagy más részekre, illetve ne húzzák fel magukat vagy ne lógnak le róluk.
- A bútork a következő maximális terhelésekre alkalmas: Ágyak (matracbetétként): 100 kg, komód: 110 kg, éjjeliszekrény és komód felsők: 15 kg, ívegpólcok: 1 kg, falpanelek: tipustól függően, fiókok: 5 kg, beépített pólcok: 10 kg, ruhatartó sín: 40 kg, fali szekrények: 20 kg, ruhanemű: 10 kg, ágymennytartók: 10 kg.

**⚠ SVK - slovenský UPOZORNENIE - BEZPEČNOSTNÉ UPOZORNENIE**

**Nábytok, ktorý nie je správne zmontovaný alebo sa nepoužíva podľa určenia, môže byť životu nebezpečný. Preto je potrebné dodržiavať nasledujúce bezpečnostné pokyny:**

- Nábytok musí montovať kvalifikovaný personál podľa montážneho návodu. Skrutky sa nesmú príliš utahovať. Počas montáže držte deti mimo dosahu.
- Všetky obaly sa musia otvoriť a musia sa prečítať všetky montážne pokyny a bezpečnostné pokyny. Tieto dokumenty sa musia uchovávať na bezpečnom mieste. Na montáž sa môžu používať len originálne diely.
- Nábytok s priloženými nástennými úchytmi musí byť pripevnený k stene. Nábytok s priloženými nástennými úchytmi musí byť pripevnený k stene.
- Nábytok skrýva nebezpečenstvo pre deti: Preto dajte na to, aby deti nelezli do zásuviek alebo na iné časti, aby sa na ne nevyťahovali alebo sa z nich nezavesovali.
- Nábytok je vhodný pre nasledujúce maximálne zaťaženia: (na matrac): (na matraci): 100 kg, komoda: 110 kg, desky nočných stolíkov a komody: 15 kg, sklenené police: 1 kg, stenové panely: v závislosti od typu, zásuvky: 5 kg, vstavané police: 10 kg, kofajničky na šaty: 40 kg, nástenné skrinky: 20 kg, výtah na šaty: 10 kg, zásuvky postele: 10 kg.

**⚠ SRB - Srpski UPOZORENJE - SIGURNOSNA OBAVEŠTENJA**

**Nameštaj koji nije pravilno sastavljen ili korišćen prema nameni može biti opasan po život. Kako biste izbegli ovu opasnost i smanjili rizik od povreda, važno je pridržavati se sledećih sigurnosnih uputstava:**

- Nameštaj mora sastaviti kvalifikovano osoblje prema uputstvima za sastavljanje. Vijci se ne smeju previše zategnuti. Držite decu na udaljenosti prilikom montaže.
- Svi paketi moraju biti otvoreni i pročitana sva uputstva za sastavljanje i sigurnosna uputstva. Ovi dokumenti se moraju čuvati. Za montažu su dopušteni samo originalni delovi.
- Nameštaj sa uključivim okovom za postavljanje na zid mora biti pričvršćen na zid u organizaciji kupca. Morate se pridržavati priloženih sigurnosnih uputstava.
- Nameštaj predstavlja potencijalnu opasnost za decu. Zbog toga, obezbedite da se decu ne penju po fiokama ili drugim delovima nameštaja, da se ne povlače ili vise na njima.
- Nameštaj je pogodan za sledeća maksimalna opterećenja: Kreveti (po bazi kreveta): -100 kg; klupe: -110 kg; noćni ormarići i dodaci za komode: -15 kg; staklene police: -1 kg; zidne police u zavisnosti od vrste: -5 kg; ugradne police: -10 kg; garderobna šipka za odeću: -40 kg; zidne jedinice: -20 kg; podizač odeće: -10 kg; police za krevet: -10 kg.

## ⚠️ LTU - LIETUVIŲ ĮSPĖJIMAS - SAUGOS PASTABA

Netinkamai sumontuoti arba ne pagal paskirtį naudojami baldai gali kelti pavojų gyvybei. Norint išvengti šio pavojaus ir sumažinti susižalojimo riziką, būtina laikytis toliau pateiktų saugos nurodymų:

- Baldus turi surinkti kvalifikuoti darbuotojai pagal surinkimo instrukcijas. Negalima per daug priveržti varžtų. Surinkimo metu vaikai turi būti atokiau.
- Visos pakuočės turi būti atidarytos ir perskaitytos visos surinkimo instrukcijos bei saugos nurodymai. Šie dokumentai turi būti laikomi saugioje vietoje. Montuojant galima naudoti tik originalias dalis.
- Baldai su pridėtamais sieniniais tvirtinimo elementais turi būti pritvirtinti prie sienos. Būtina laikytis pridėdamų saugos instrukcijų dėl tvirtinimo prie sienos.
- Baldai kelia pavojų vaikams: todėl pasirūpinkite, kad vaikai neliptų į stalčius ar kitas jų dalis, nesikeltų į juos ir nesikabinėtų ant jų.
- Baldai tinka toliau nurodytoms didžiųjų apr科夫oms: lovos (vienam čiužiniui): 100 kg, komoda: 110 kg, naktinių stalčių ir komodų stalviršiai: 15 kg, stiklinės lentynos: 1 kg, sieninės plokštės: (priklausomai nuo tipo), stalčiai: 5 kg, įmontuotos lentynos: 10 kg, drabužių bėgeliai: 40 kg, sieninės spintelės: 20 kg, drabužių keltuvas: 10 kg, lovos stalčiai: 10 kg.

## ⚠️ MLT - MALTI TWISSJA - AVVIŻ TAS-SIGURTÀ

Għamara li mhix immuntata sew jew użata għall-iskop maħsub tagħha tista 'tkun ta' theddida għall-ħajja. Għalhekk, l-Istruzzjonijiet tas-sigurtà li ġejjin għandhom jiġu osservati:

- L-għamara għandha tkun immuntata minn personal kwalifikat bl-użu tal-istruzzjonijiet tal-assemblaġġ. Il-viti m'għandhomx jiġu sikkati żżejjed. It-tfal għandhom jinżammu 'l bogħod waqt l-assemblaġġ.
- Il-pakketti kollha għandhom jinfehta u l-instruzzjonijiet kollha tal-assemblaġġ u l-istruzzjonijiet tas-sigurtà jinqraw. Dawn id-dokumenti għandhom jinżammu. Partijiet originali biss huma permessi għall-assemblaġġ.
- Għamara b'immuntar fuq il-ħajt inkluż għandha itwahaħ mal-ħajt. L-istruzzjonijiet tas-sigurtà magħluqa għall-immuntar mal-ħajt għandhom jiġu osservati.
- L-għamara tohloq perikli għat-tfal: Jekk jogħġbok kun żgur li t-tfal ma jittigħux fil-kxaxen jew partijiet oħra, jiġbdu lihom infushom jew jiddendlu magħhom.
- L-għamara hija adattata għat-tagħbijiet massimi li ġejjin: Sodod (għal kull topper tas-saqqu): 100 kg, sedli tal-dresser: 110 kg, komodini u aċċessorji tal-dresser: 15 kg, kxaġef tal-ħġeġ: 1 kg, pannelli tal-ħajt: skont il-tip, kxaxen: 5 kg, kxaġef inkorporati: 10 kg, linji tal-hwejjeġ: 40 kg, għamara tal-ħajt: 20 kg, lift tal-hwejjeġ: 10 kg, kxaxen tas-sodda: 10kg.

## ⚠️ ROU - ROMÂN AVERTIZARE - NOTĂ DE SIGURANȚĂ

Mobila care nu este asamblată corect sau care nu este utilizată conform destinației poate pune viața în pericol. Prin urmare, trebuie respectate următoarele instrucțiuni de siguranță:

- Mobila trebuie asamblată de personal calificat însoțind instrucțiunile de asamblare. Șuruburile nu trebuie strânse prea tare. Copiii trebuie ținuti departe în timpul asamblării.
- Toate ambalajele trebuie deschise și trebuie citite toate instrucțiunile de asamblare și instrucțiunile de siguranță. Aceste documente trebuie păstrate într-un loc sigur. Pentru asamblare pot fi utilizate numai piese originale.
- Mobilierul cu elemente de fixare pe perete include trebuie să fie fixat pe perete. Trebuie respectate instrucțiunile de siguranță anexate pentru montarea pe perete.
- Mobila ascunde pericole pentru copii: prin urmare, asigurați-vă că copiii nu se urcă în sertare sau pe alte părți, nu se trag în sus sau nu se agată de ele.
- Mobilierul este adecvat pentru următoarele sarcini maxime: Paturi (per topper saltea): 100 kg, comodă: 110 kg, blaturi pentru noptieră și comodă: 15 kg, rafturi din sticlă: 1 kg, panouri de perete: în funcție de tip, sertare: 5 kg, rafturi încorporate: 10 kg, bare pentru haine: 40 kg, unități de perete: 20 kg, ridicător de haine: 10 kg, sertare de pat: 10 kg.

## ⚠️ SWE - SVENSKA VARNING - SÄKERHETSMEDELLENDE

Möbler som inte är korrekt monterade eller som inte använts på avsett sätt kan vara livsfarliga. För att undvika denna fara och minska risken för skador är det viktigt att följa följande säkerhetsanvisningar:

- Möblerna måste monteras av kvalificerad personal enligt monteringsanvisningarna. Skruvarna får inte dras åt för hårt. Barn ska hållas borta under monteringen.
- Alla förpackningar måste öppnas och alla monteringsanvisningar och säkerhetsanvisningar måste läsas. Dessa dokument måste förvaras på ett säkert ställe. Endast originaldelar får användas vid monteringen.
- Möbler med medförlagda väggfästen måste fästas i väggen. Beakta bifogade säkerhetsanvisningar för väggmontering.
- Möbler innebär faror för barn: Se därför till att barn inte klättrar in i lådor eller på andra delar och inte heller drar sig upp eller hänger i dem.
- Möblerna är lämpliga för följande maximala belastningar: Sängar (per bäddmadrass): 100 kg, byrå: 110 kg, nattduksbord och byråskivor: 15 kg, glashyllor: 1 kg, väggpaneler: beroende på typ, lådor: 5 kg, inbyggda hyllor: 40 kg, klädstångar: 40 kg, väggskåp: 20 kg, klädlyft: 10 kg, sänglådor: 10 kg.

## ⚠️ GRC - ελληνικά ΠΡΟΕΙΔΟΠΟΙΗΣΗ - ΟΔΗΓΙΕΣ ΑΣΦΑΛΕΙΑΣ

Τα έπιπλα που δεν έχουν συναρμολογηθεί σωστά ή δεν χρησιμοποιούνται όπως προβλέπεται μπορεί να είναι απειλητικά για τη ζωή. Επομένως, πρέπει να τηρούνται οι ακόλουθες οδηγίες ασφαλείας:

- Τα έπιπλα πρέπει να συναρμολογηθούν από εξειδικευμένο προσωπικό σύμφωνα με τις οδηγίες συναρμολόγησης. Οι βίδες δεν πρέπει να αφιρτώνται υπερβολικά. Τα παιδιά πρέπει να είναι μακριά κατά τη συναρμολόγηση.
- Όλες οι συσκευασίες πρέπει να είναι ανοιχτές και όλες οι οδηγίες συναρμολόγησης και οι οδηγίες ασφαλείας πρέπει να διαβάζονται και να φυλάσσονται σε ασφαλές μέρος. Για τη συναρμολόγηση επιτρέπεται να χρησιμοποιούνται μόνο γνήσια εξαρτήματα.
- Τα έπιπλα με κλειστά επιτοιχία εξαρτήματα πρέπει να στερεώνονται στον τοίχο. Πρέπει να τηρούνται οι συνημμένες οδηγίες ασφαλείας για την τοποθέτηση στον τοίχο.
- Τα έπιπλα κρϋβουν κινδύνους για τα παιδιά: Για το λόγο αυτό, βεβαιωθείτε ότι τα παιδιά δεν σκαρφαλώνουν στα συρτάρια ή σε άλλα μέρη ή δεν τραβιούνται ή κρέμονται από αυτά.
- Τα έπιπλα είναι κατάλληλα για τα ακόλουθα μέγιστα φορτία: Κρεβάτια (ανά επικάλυψη στρώματος): συρτάρια: 110 kg, κομοδίνα και συρτάρια: 15 kg, γυάλινα ράφια: 1 kg, επιτοιχία πάνελ: ανάλογα με τον τύπο, συρτάρια: 5 kg, ενσωματωμένα ράφια: 10 kg, ράφες ρούχων: 40 kg, επιτοιχία έπιπλα: 20 kg, ανυψωτικό ρούχων: 10 kg, συρτάρια κρεβατιού: 10 kg.

## ⚠️ IRL - GAELIGE RABHADH - FÓGRA SÁBHÁILTEACHTA

Is féidir le troscán nach gcuirtear le chéile i gceart nó nach n-úsáidtear chun na críche atá beartaithe dó a bheith bagrach don bheatha. Dá bhri sin, ní mór cloi leis na treoracha sábháilteachta seo a leanas:

- Ní mór do phearsnach cáilithe an troscán a chur le chéile ag baint úsáide as na treoracha tionól. Níor cheart scrúinú a róthéamh. Ní mór leanai a choinneáil ar shiúl le linn tionóil.
- Ní mór gach pacáiste a oscailt agus gach treoir tionóil agus treoracha sábháilteachta a léamh. Ní mór na doiciméid seo a choinneáil. Ní cheadaítear ach páirteanna bunaidh a chur le chéile.
- Ní mór troscán le gléasadh balla san áireamh a cheangal leis an mballa. Ní mór cloi leis na treoracha sábháilteachta iniata le haghaidh gléasta balla.
- Tá contúirtí ag baint le troscán do leanai: Cinntigh le do thoil nach dtógfaidh leanai isteach i drawers nó páirteanna eile, go dtarraingíonn siad suas iad féin nó nach gcloifidh siad leo.
- Tá an troscán oiriúnach do na hualái uasta seo a leanas: Leapaoha (in aghaidh an topper tochta): 100 kg, suíocháin gúna: 110 kg, táblaí cois leapa agus ceangaltáin gúna: 15 kg, seilfeanna gloine: 1 kg, painéil balla: ag brath ar an gceinéal, tarraiceán: 5 kg, Seilfeanna insuite: 10 kg, ráillí éadaí: 40 kg, troscán balla: 20 kg, ardaitheoir éadaí: 10 kg, tarraiceáin leaba: 10kg.

## ⚠️ HRV - Hrvatski UPOZORENJE - SIGURNOSNA OBAVIJEST

Namještaj koji nije pravilno sastavljen ili korišten prema namjeni može biti opasan po život. Kako biste izbjegli ovu opasnost i smanjili rizik od ozljeda, važno je pridržavati se sljedećih sigurnosnih uputa:

- Namještaj mora sastaviti kvalificirano osoblje prema uputama za sastavljanje. Vijci se ne smiju previše zategnuti. Az őszeszerezelés során a gyerekekét távol kell tartani.
- Sva pakiranja moraju biti otvorena i pročitate sve upute za sastavljanje i sigurnosne upute. Ovi dokumenti moraju se čuvati. Za montažu su dopušteni samo originalni dijelovi.
- Namještaj s uključenom montažom na zid mora biti pričvršćen na zid. Morate se pridržavati priloženih sigurnosnih uputa za zidnu montažu.
- Namještaj predstavlja opasnost za djecu: Pazite da se djeca ne penjju u ladice ili druge dijelove, da se ne povlače ili vise na njima.
- Namještaj je prikladan za sljedeća maksimalna opterećenja: Kreveti (po nadmadracu): 100 kg, sjedala za komode: 110 kg, noćni ormarići i dodaci za komode: 15 kg, staklene police: 1 kg, zidne ploče: ovisno o vrsti, ladice: 5 kg, ugradbene police: 10 kg, šipke za odjeću: 40 kg, zidni namještaj: 20 kg, podizač odjeće: 10 kg, ladice za krevet: 10 kg.

## ⚠️ LVA - Latviešu BRĪDINĀJUMS - DROŠĪBAS INSTRUKCIJAS

Mēbeles, kas nav pareizi samontētas vai netiek lietotas atbilstoši paredzētajam mērķim, var apdraudēt dzīvību. Lai izvairītos no šādām briesmām un samazinātu traumu risku, ir svarīgi ievērot turpmāk minētos drošības norādījumus:

- Mēbeles jāsamontē kvalificētam personālam saskaņā ar montāžas instrukcijām. Skrūves nedrīkst pārspīlēt. Montāžas laikā bērniem jābūt prom.
- Jāatver visi iepakojumi un jāizlasa visas montāžas instrukcijas un drošības norādījumi. Šie dokumenti jāglabā drošā vietā.
- Mēbeles ar pievienotiem sienas stiprinājumiem jāpiestiprina pie sienas. Jāievēro pievienotie drošības norādījumi par montāžu pie sienas.
- Mēbeles slēpj briesmas bērniem: tāpēc pārliecinieties, ka bērni neļien atvilktnēs vai uz citām mēbeļu daļām, nevelk uz tām vai karājas uz tām.
- Mēbeles ir piemērotas šādām maksimālajām slodzēm: Gultas (uz matrača pārvalka): 100 kg, kumodes: 110 kg, naktsskapīsu un kumodes virsmas: 15 kg, stikla plaukti: 1 kg, sienas paneļi: atkarībā no tipa, atvilktnes: 5 kg, iebūvētie plaukti: 10 kg, drēbju pakaramie: 40 kg, sienas skapīši: 20 kg, drēbju pacelājs: 10 kg, gultas atvilktnes: 10 kg.

## ⚠️ BGR - Български ПРЕДУПРЕЖДЕНИЕ - ИНСТРУКЦИИ ЗА БЕЗОПАСНОСТ

Мебели, които не са сглобени правилно или не се използват по предназначение, могат да бъдат опасни за живота. Следователно трябва да се спазват следните инструкции за безопасност:

- Мебелите трябва да се сглобяват от квалифициран персонал в съответствие с инструкциите за сглобяване. Винтовете не трябва да се затягат прекалено. Децата трябва да се държат настрана по време на монтажа.
- Всички опаковки трябва да бъдат отворени и всички инструкции за монтаж и безопасност трябва да бъдат прочетени и съхранявани безопасно. За сглобяване могат да се използват само оригинални части.
- Мебелите с вградени приспособления трябва да бъдат закрепени към стената. Трябва да се спазват приложените инструкции за безопасност при монтаж на стена.
- Мебелите крият опасности за децата: Затова се уверете, че децата не се катерят по чекмеджетата или по други части, не се издърпват или не висят от тях.
- Мебелите са подходящи за следните максимални натоварвания: легла (за един топ матрац): 100 кг, скрин: 110 кг, плотове за нощни шкафчета и скрин: 15 кг, стъклени рафтове: 1 кг, стени панели: в зависимост от вида, чекмеджета: 5 кг, вградени рафтове: 10 кг, релси за дрехи: 40 кг, стени шкафове: 20 кг, подемник за дрехи: 10 кг, чекмеджета за легла: 10 кг.

## ⚠️ DNK - Dansk ADVARSEL - SIKKERHEDSINSTRUKTIONER

Møbler, der ikke er samlet korrekt eller ikke anvendes efter hensigten, kan være livsfarlige. For at undgå denne fare og reducere risikoen for skader skal følgende sikkerhedsanvisninger overholdes:

- Møblerne skal samles af kvalificeret personale i overensstemmelse med monteringsvejledningen. Skruer må ikke overspændes. Børn skal holdes væk under monteringen.
- Alle pakker skal åbnes, og alle monteringsanvisninger og sikkerhedsanvisninger skal læses. Disse dokumenter skal opbevares på et sikkert sted. Der må kun bruges originale dele til monteringen.
- Møbler med vedlagte vægbeslag skal fastgøres til væggen. De vedlagte sikkerhedsanvisninger for vægmontering skal overholdes.
- Møbler rummer farer for børn: Sørg derfor for, at børn ikke kravler ind i skuffer eller på andre dele eller trækker sig op eller hænger i dem.
- Møblerne er egnede til følgende maksimale belastninger: Senge (pr. topmadræs): 100 kg, kommode: 110 kg, natbords- og kommodeplader: 15 kg, glashylder: 1 kg, vægpaneler: afhængigt af type, skuffer: 5 kg, indbyggede hylder: 10 kg, bøjlestænger: 40 kg, overskabe: 20 kg, tøjlift: 10 kg, sengeskuffer: 10 kg.

## ⚠️ EST - Eesti HOIATUS - OHUTUSJUHISED

































Korrektselt kokku panemata või mitte ettenähtud viisil kasutatav mööbel võib olla eluohtlik. Selle ohu vältimiseks ja vigastusohu vähendamiseks on oluline järgida järgmisi ohutusjuhiseid:

























- Mööblit peavad monteerima kvalifitseeritud töötajad vastavalt monteerimisjuhendile. Krusivide ei tohi üle pingutada. Lapsed tuleb kokkupaneku ajal eemal hoida.
- Kõik pakendid tuleb avada ning lugeda kõiki koostamisjuhiseid ja ohutusjuhiseid. Neid dokumente tuleb hoida turvalises kohas. Kokkupanekus tohib kasutada ainult originaalosi.
- Kinnitatud seinakinnitustega mööbel tuleb kinnitada seinale külge. Tuleb järgida lisatud ohutusjuhiseid seinakinnituste kohta.
- Mööbel käitkeb endas ohte lastele: seepärast veenduge, et lapsed ei roni sahtlitesse või muudesse osadesse, ei tõmba end üles ega ripu nende külge.
- Mööbel sobib järgmistele maksimaalsetele koormustele jaoks: Voodid (ühel madratsitopperi kohta): 100 kg, kapp: 110 kg, öökappide ja kappide laud: 15 kg, klaasriiulid: 1 kg, seinapaneelid: sõltuvalt tüübist, sahtlid: 5 kg, sisseehitatud riiulid: 10 kg, riideriulid: 40 kg, seinapaneelid: 20 kg, riitelifti: 10 kg, voodisahtlid: 10 kg.

























## ⚠️ FIN - suomalainen VAROITUS - TURVALLISUUSOHJEET

























Huonekalut, joita ei ole koottu oikein tai joita ei käytetä tarkoitettulla tavalla, voivat olla hengenvaarallisia. Tämän vaaran välttämiseksi ja loukkaantumisriskin vähentämiseksi on noudatettava seuraavia turvallisuusohjeita:

























- Pätevän henkilöstön on koottava kalusteet kokoonpano-ohjeiden mukaisesti. Ruuveja ei saa kiristää liikaa. Lapset on pidettävä loitolla kokoamisen aikana.
- Kaikki pakkaukset on avattava ja kaikki kokoonpano- ja turvallisuusohjeet on luettava. Nämä asiakirjat on säilytettävä turvallisessa paikassa. Kokoonpanossa saa käyttää vain alkuperäisiä osia.
- Huonekalut, joissa on mukana seinäkinnikkeet, on kinnitettävä seinään. Oheisia seinäkinnitystä koskevia turvallisuusohjeita on noudatettava.
- Huonekaluihin liittyy vaaroja lapsille: Varmista siksi, että lapset eivät kiipeile laatikoihin tai muisiin osiin eivätkä vedä itseään ylös tai roiku niistä.
- Huonekalut soveltuvat seuraaville enimmäiskuurmille: Sängyt (patjanpäällistä kohtden): Sängyt (patjanpäällistä kohtden): 100 kg, lipasto: 110 kg, yöpöydän ja lipaston yläosat: 15 kg, lasihyllyt: 1 kg, seinäpaneelit: tyyppistä riippuen, vetolaatikot: 5 kg, sisäänrakennetut hyllyt: 10 kg, vaateangot: 40 kg, seinäelementit: 20 kg, vaatehissi: 10 kg, sängyn laatikot: 10 kg.

 111 149 24x	 111 300 15x	 117 002 4x	 111 611 8x	 112 220/1 3x	 111 052 1x
 111 103 8x	 111 xxx 15x	 26x	 6,3 x 10,5 mm 36x	 M6 x 10 12x	 4 X 13mm 1x
 8x	 121 370 42x	 957mm 2x	 111 607 12x	 4 X 27mm 34x	 15x
 111 229 12x	 111 252 12x	 353 018 6x	 163 007 4x	 3 x 13 mm 12x	 111 066/074 2x
 112 265 4x	 112 268 4x	 4 X 23 mm 4x	 111 641 4x	 352 302 14x	 111 xxx 3x
 111 xxx 8x	 111 265 12x				

 L=2920 (1151/1769) 1x	 2x	 1x	 3x
 L=2920 (1151/1769) 1x	 2x	 1x	 2x
 LA12176 1x	 M4 x 13 mm 6x	 3,5 x 35 mm 2x	 4x
 LA12134 1x	 M4 x 10 mm 6x	 4 X 13mm 68x	
 LA12135 1x	 190014/015 4x	 6,3 x 10,5 mm 28x	
 LA12175 1x	 1x	 114 183 4x	
 4x	 2x	 1x	

 L=2920 (1151/1769) 1x	 2x	 1x	 3x
 L=2920 (1151/1769) 1x	 2x	 1x	 2x
 LA12176 1x	 M4 x 13 mm 6x	 3,5 x 35 mm 2x	 4x
 LA12134 1x	 M4 x 10 mm 6x	 4 X 13mm 68x	
 LA12135 1x	 190014/015 4x	 6,3 x 10,5 mm 28x	
 LA12175 1x	 1x	 114 183 4x	
 4x	 2x	 1x	

 L=2920 (1151/1769) 1x	 2x	 1x	 3x
 L=2920 (1151/1769) 1x	 2x	 1x	 2x
 LA12176 1x	 M4 x 13 mm 6x	 3,5 x 35 mm 2x	 4x
 LA12134 1x	 M4 x 10 mm 6x	 4 X 13mm 68x	
 LA12135 1x	 190014/015 4x	 6,3 x 10,5 mm 28x	
 LA12175 1x	 1x	 114 183 4x	
 4x	 2x	 1x	

 L=2920 (1151/1769) 1x	 2x	 1x	 3x
 L=2920 (1151/1769) 1x	 2x	 1x	 2x
 LA12176 1x	 M4 x 13 mm 6x	 3,5 x 35 mm 2x	 4x
 LA12134 1x	 M4 x 10 mm 6x	 4 X 13mm 68x	
 LA12135 1x	 190014/015 4x	 6,3 x 10,5 mm 28x	
 LA12175 1x	 1x	 114 183 4x	
 4x	 2x	 1x	

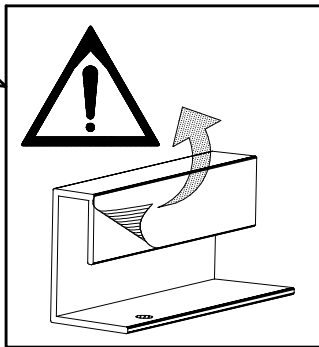
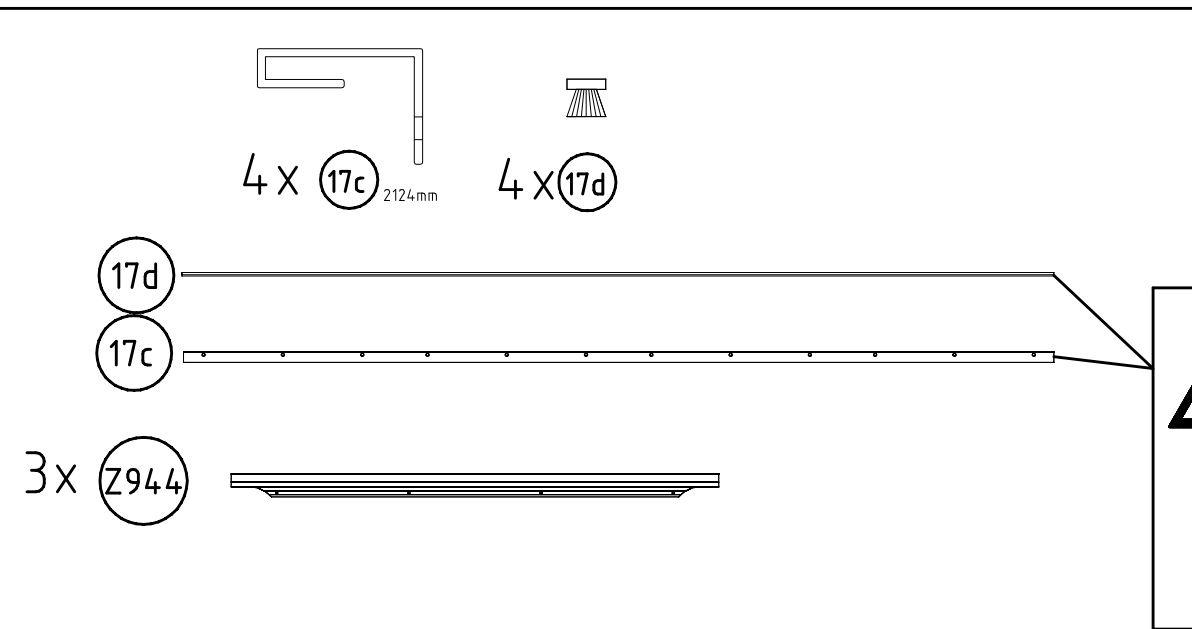
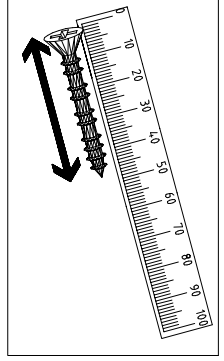
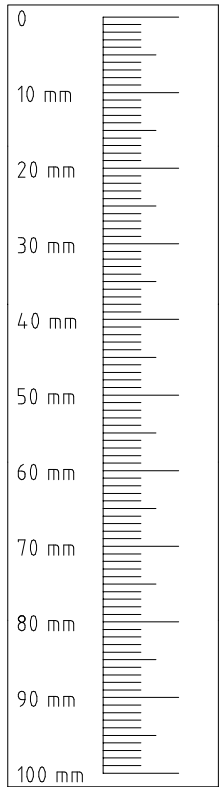
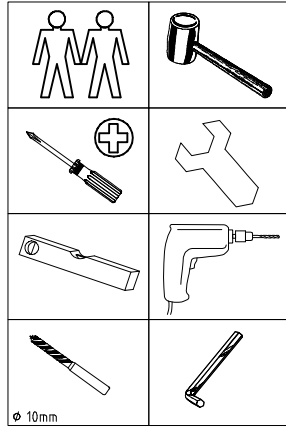

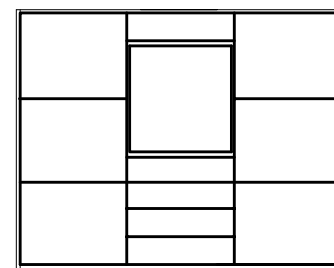
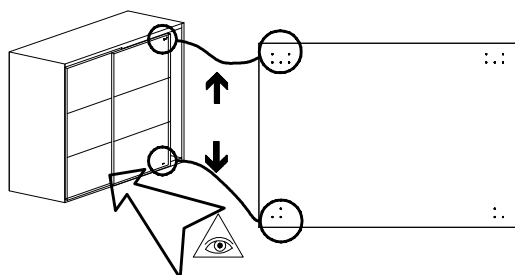
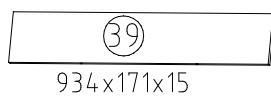
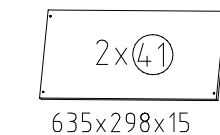
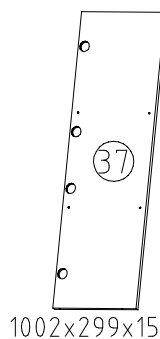
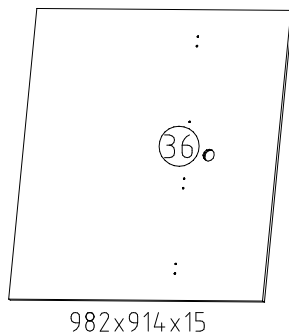
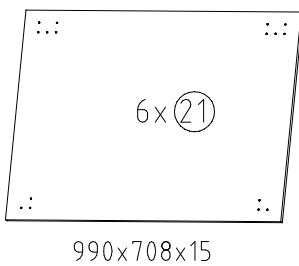
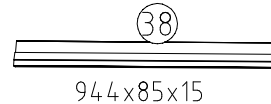
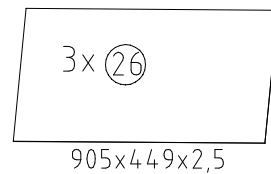
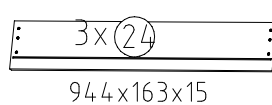
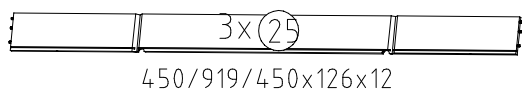
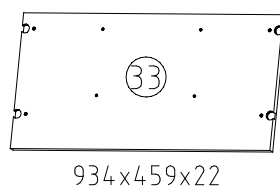
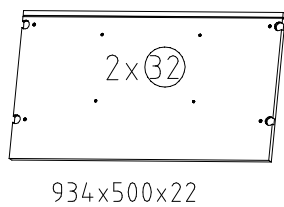
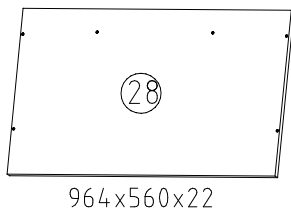
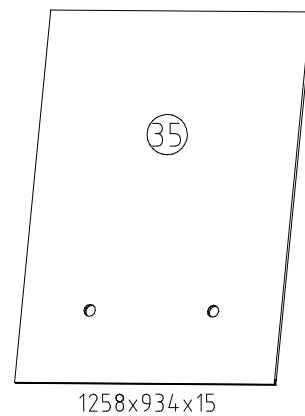
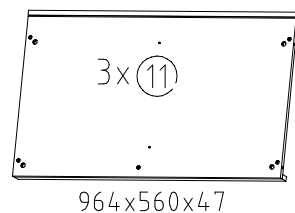
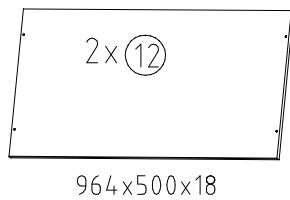
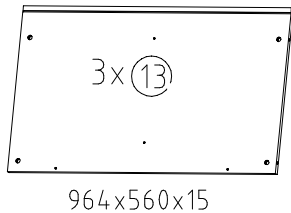
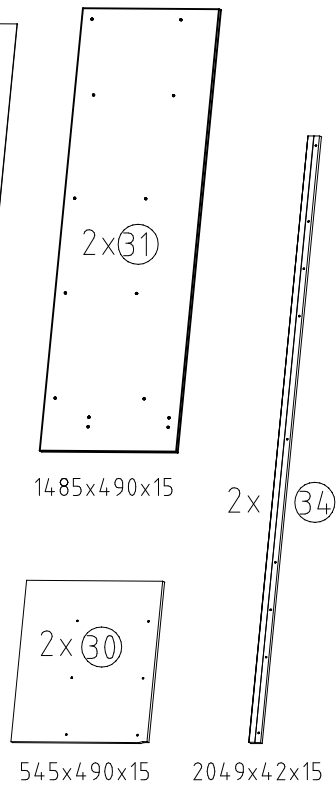
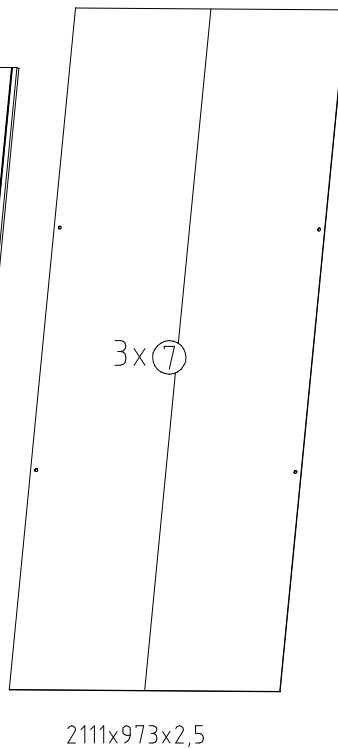
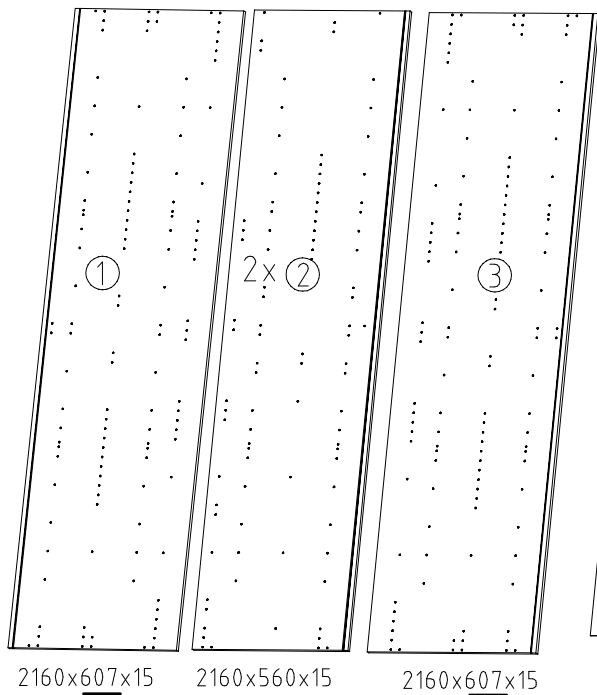

L M R

1

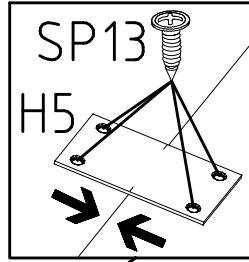
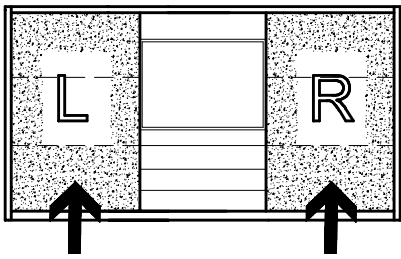

H5 4 X 13mm SP13

114 183 121 122

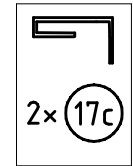
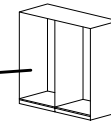
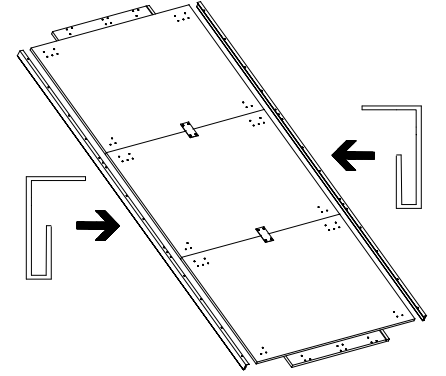
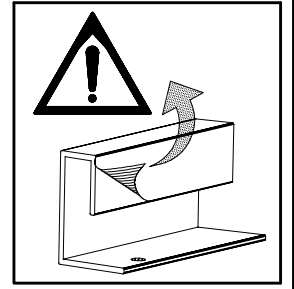
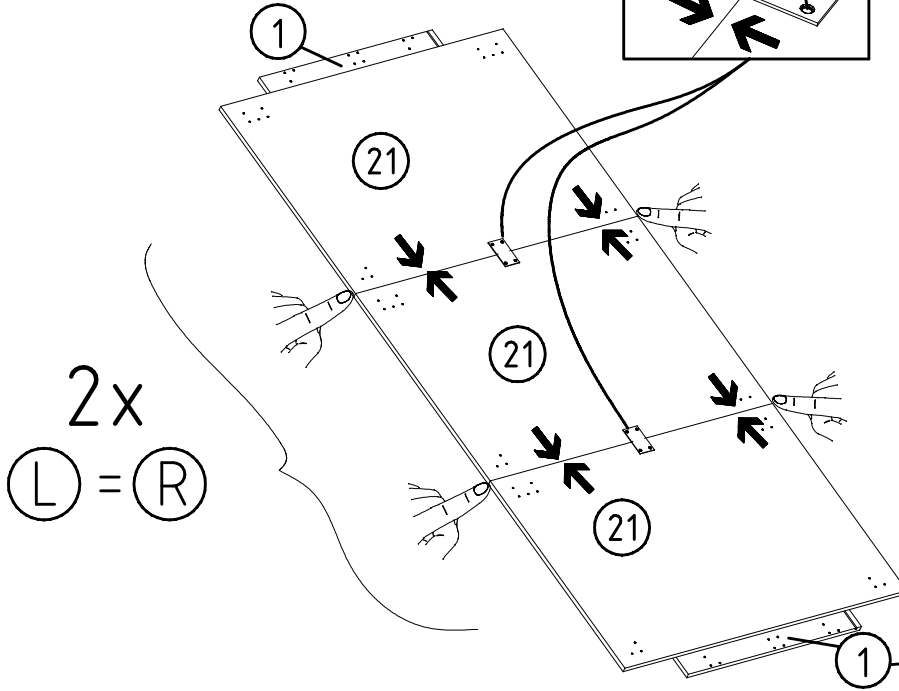

2

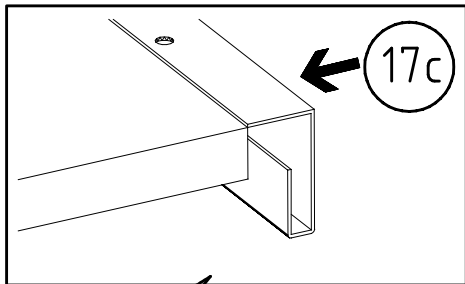

4 X 13mm SP13

121 122

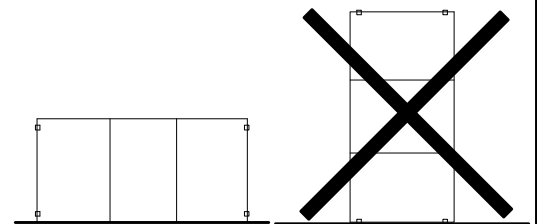
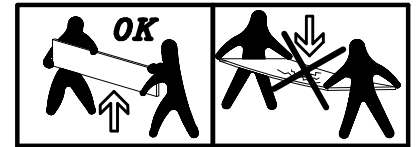
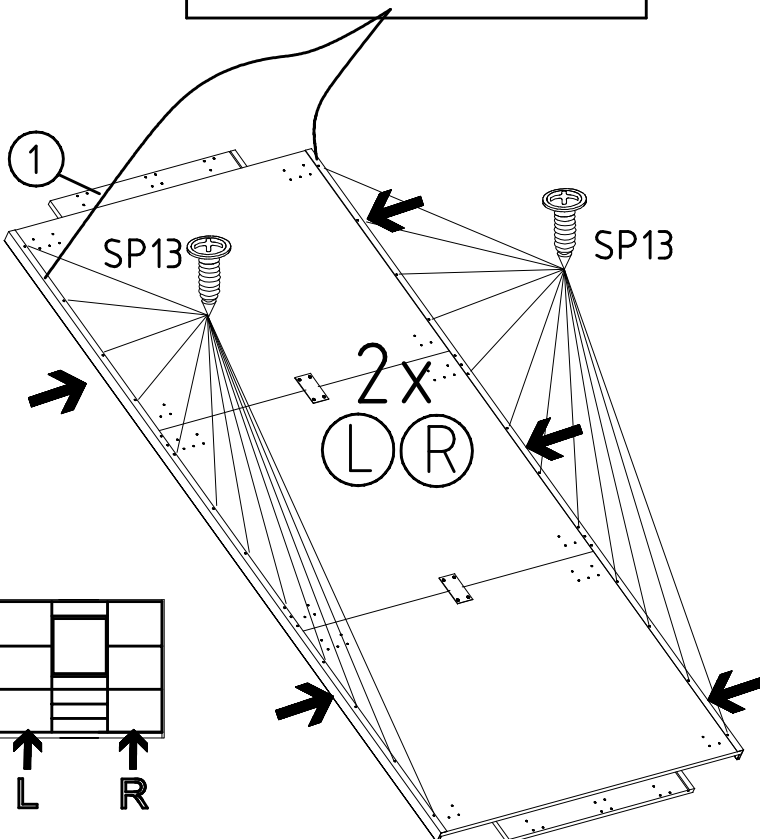
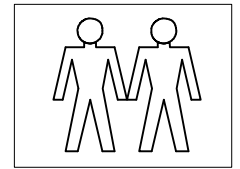

3

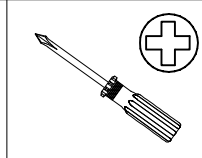
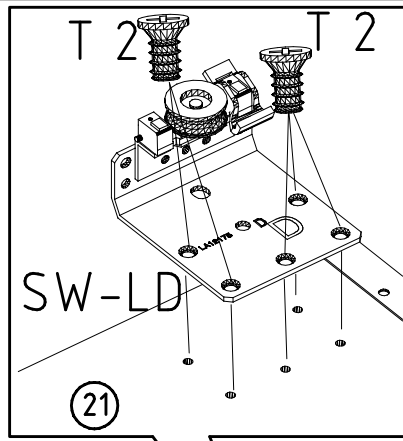
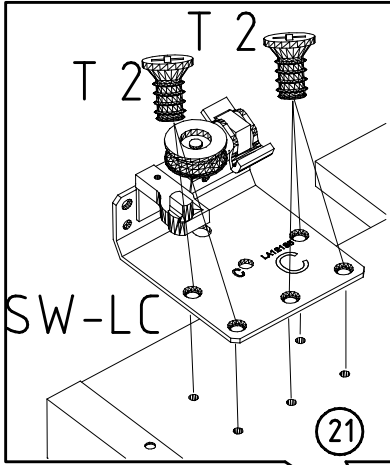

6,3 x 10,5 mm T2

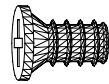

111 030 LA12135

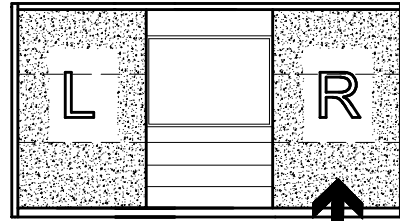
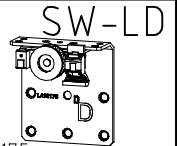
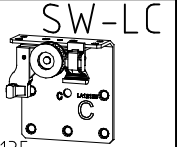

SW-F1



SW-F3

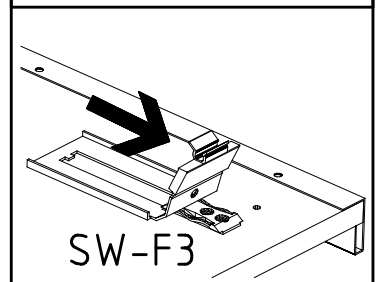
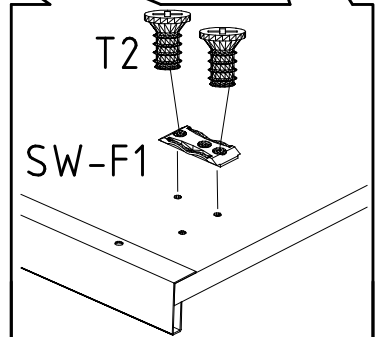
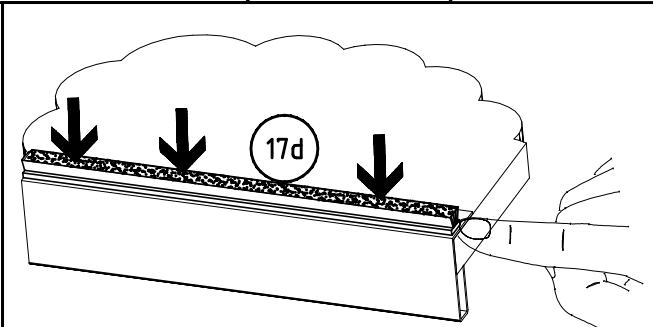
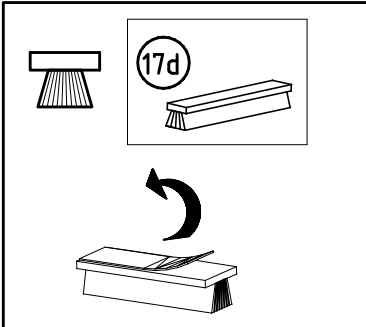
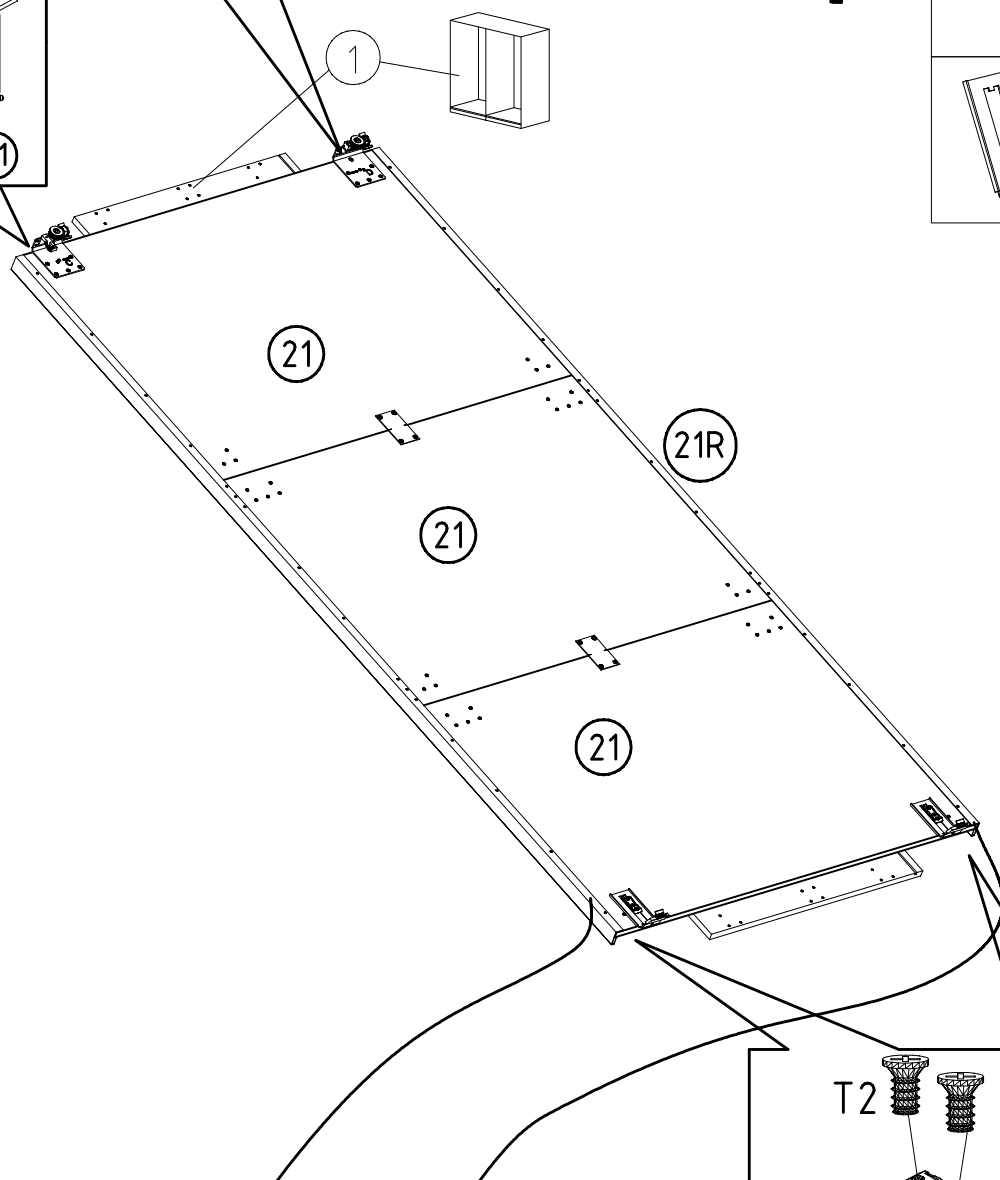
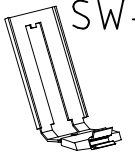

4

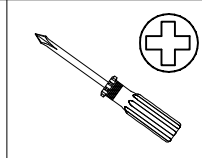
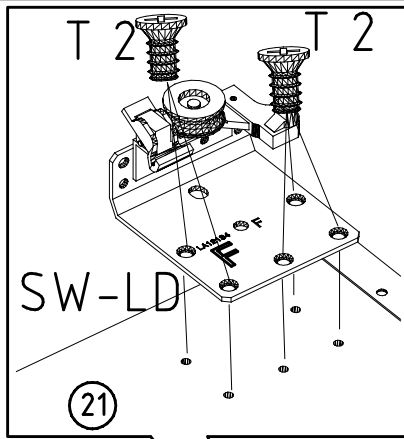
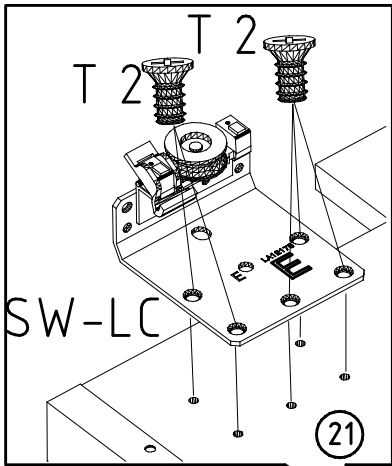

6,3 x 10,5 mm T2

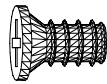

111 030 LA12176

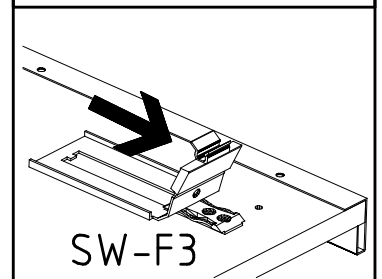
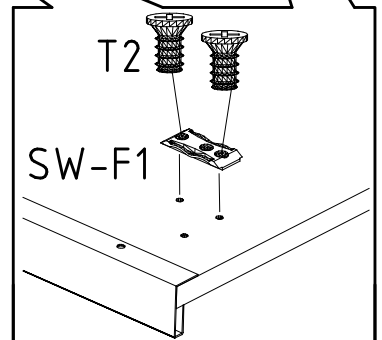
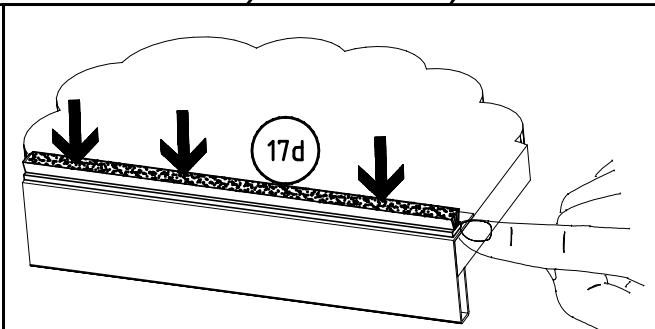
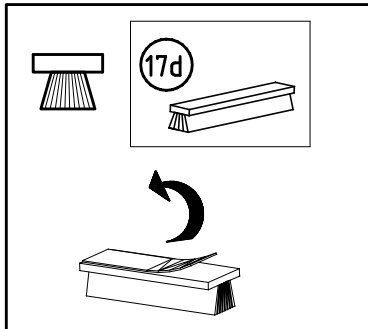
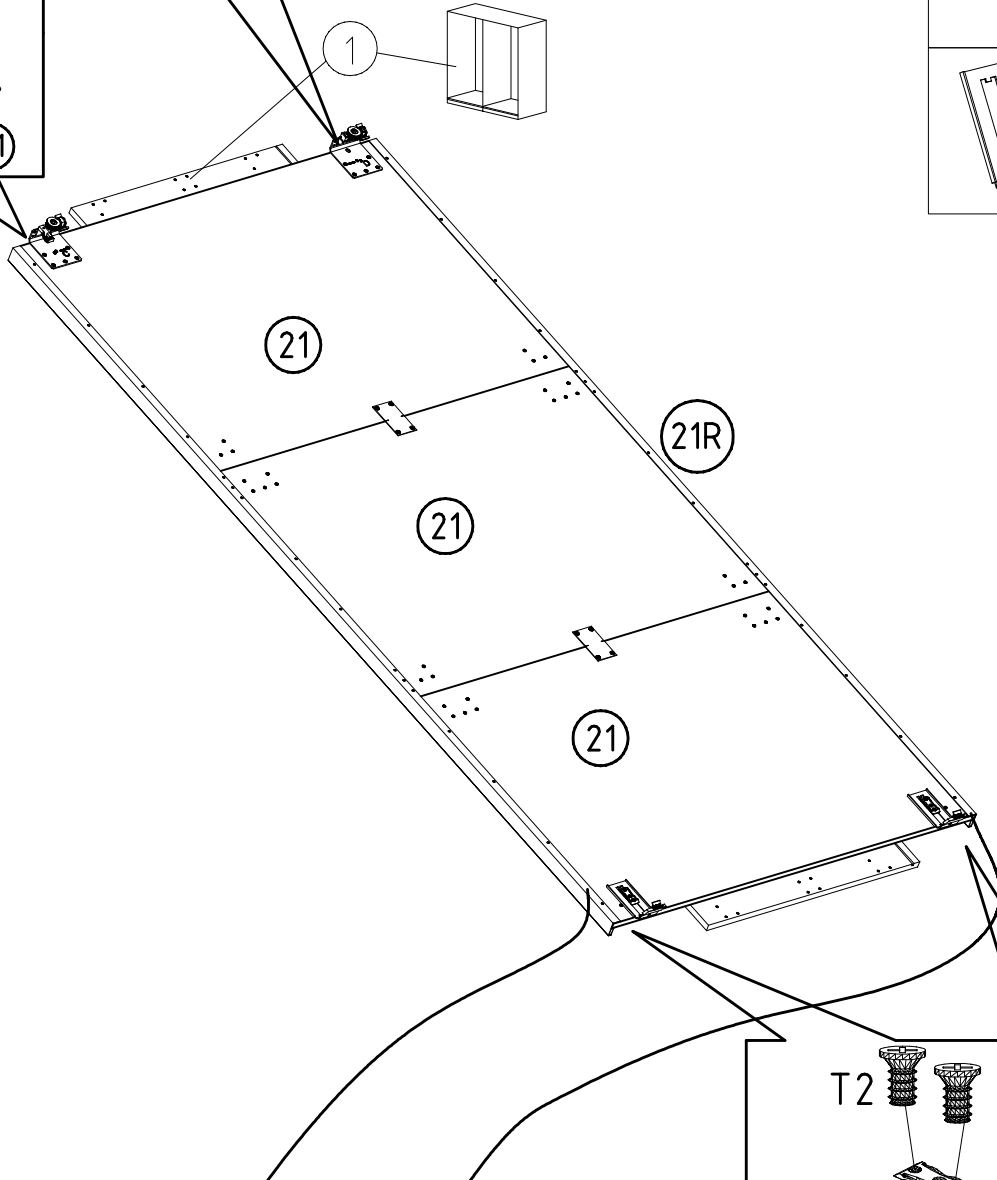
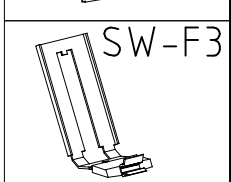
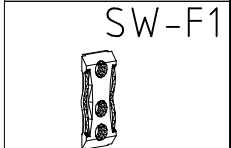
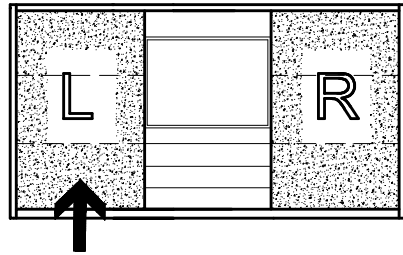
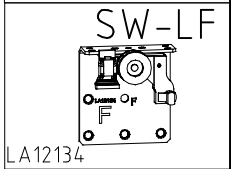
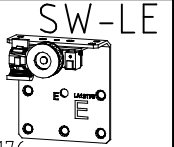

5

3,5 x 15 mm

G1

S0

A1

7

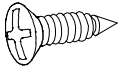

121 370

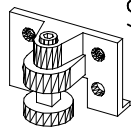

111 300



111 149

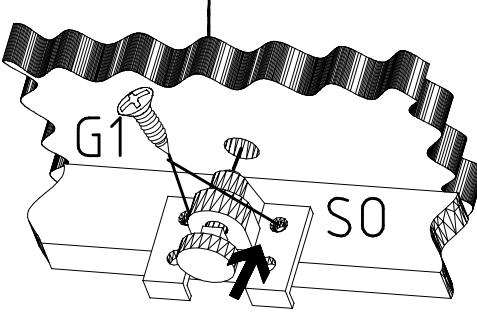
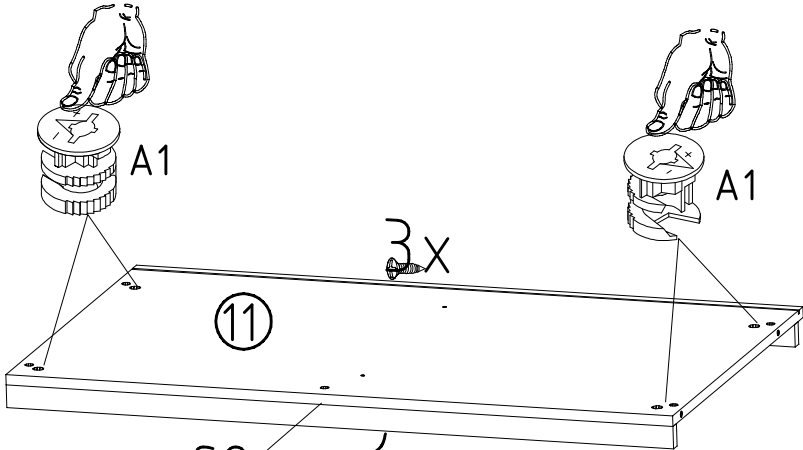

6

A1

111 149

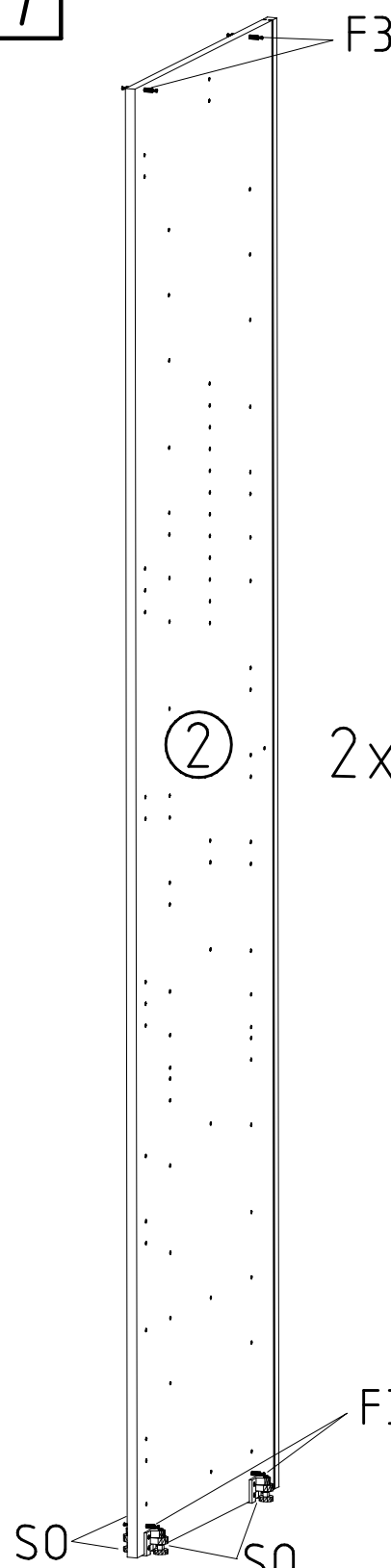
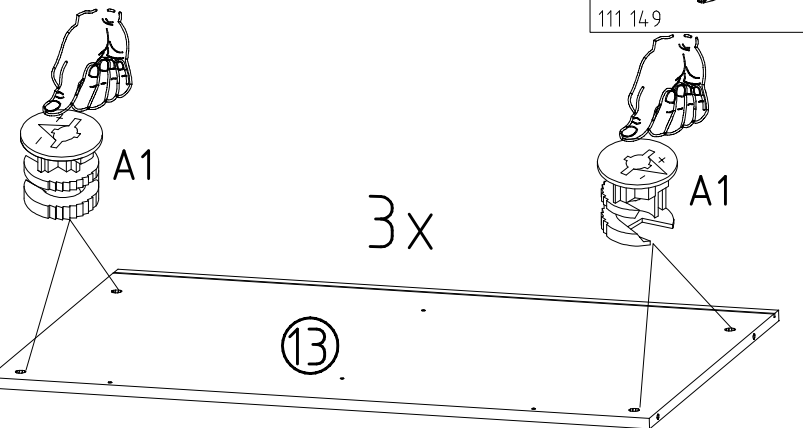

+

6,3 x 10,5 mm T1

112 055

3,5 x 15 mm G1

121 370

S0

111 300

F3

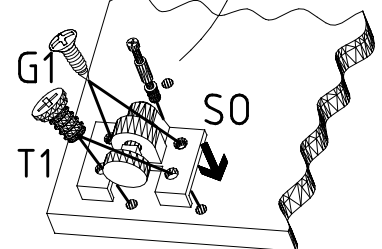
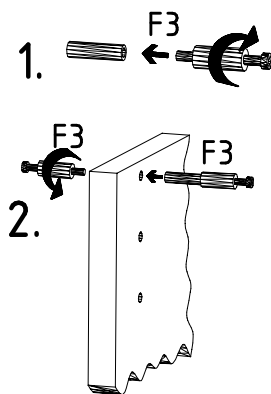

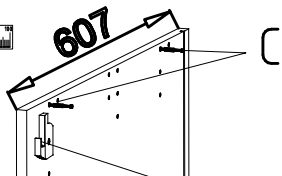
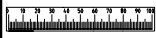
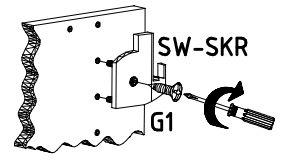
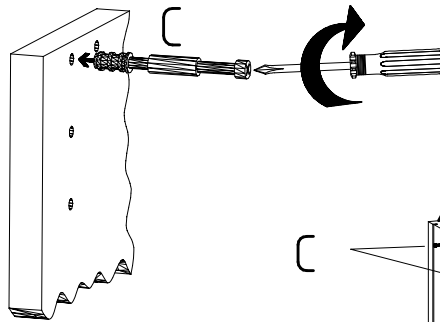
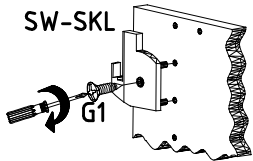

SW-SKL  
+G1

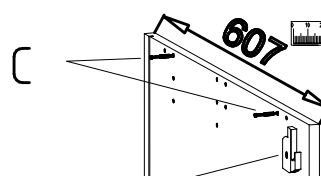

SW-SKR  
+G1

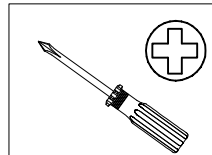

SW-SKR

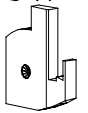

SW-SKL

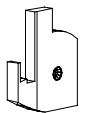

6,3 x 10,5 mm T1

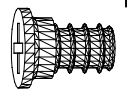

112 055

3,5 x 15 mm G1

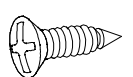

121 370

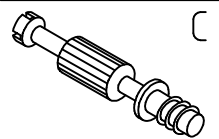

111 103

S0

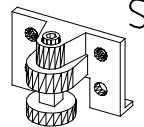

111 300

1

3

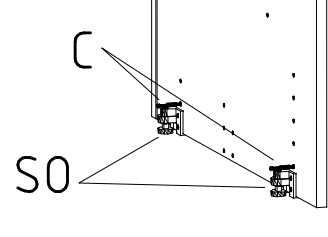
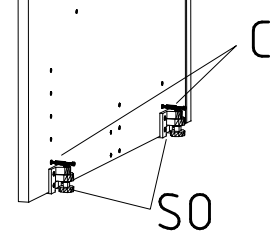
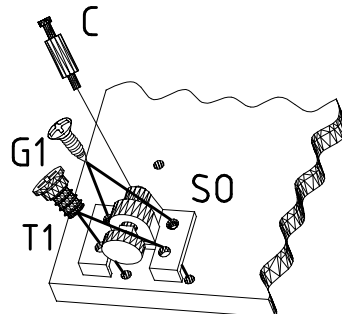

9

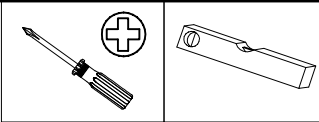

www.wimex-online.com/  
montagevideo/582020.mp4

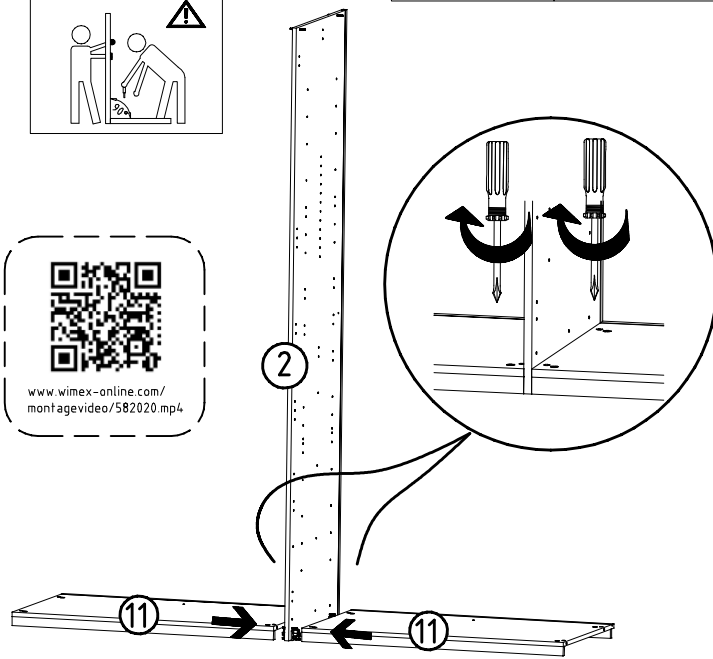

10

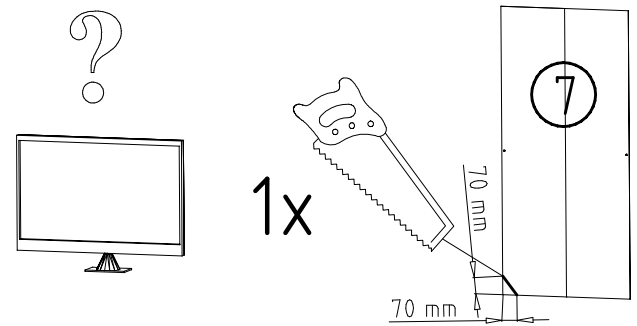
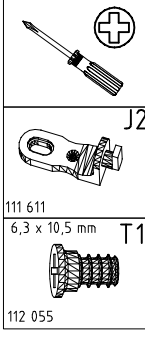
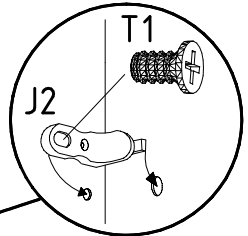
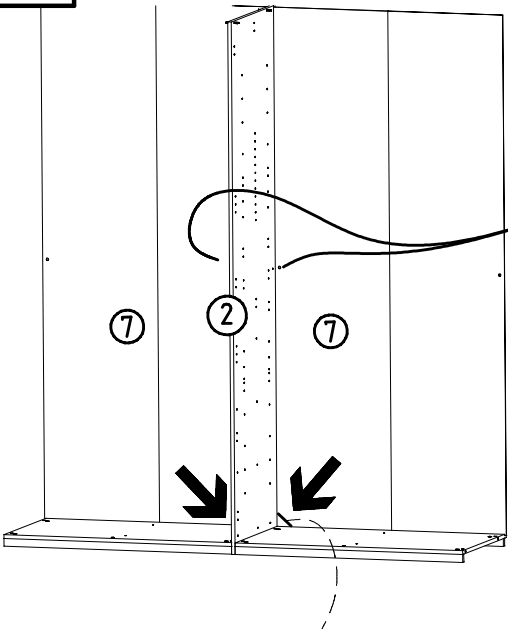

11

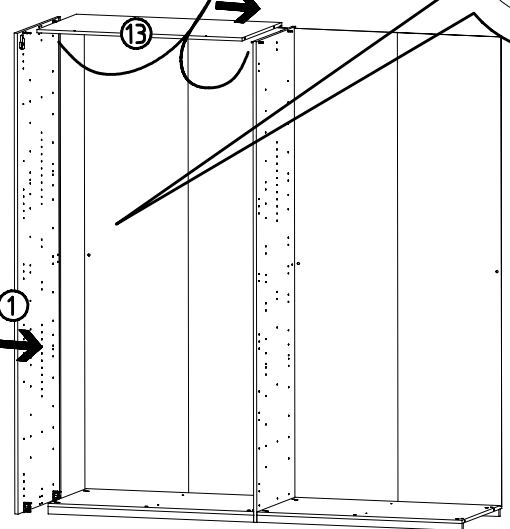
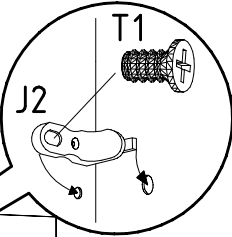
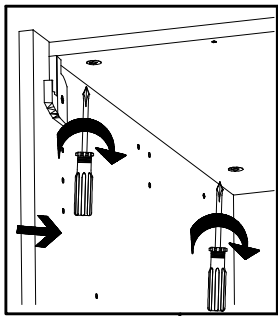
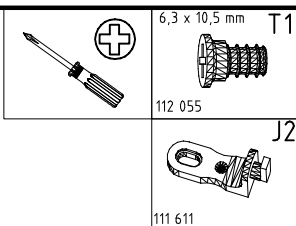

12

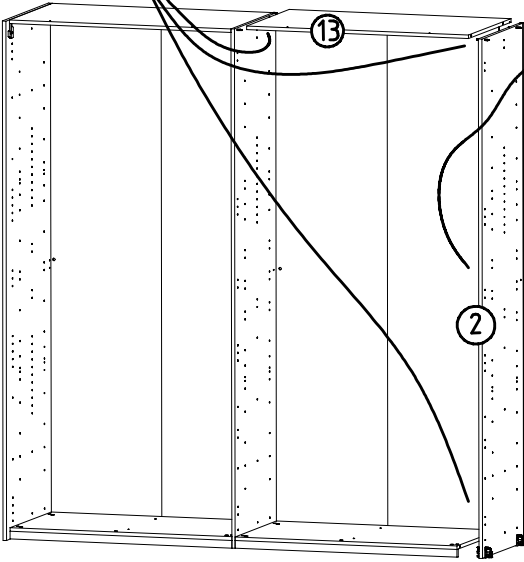
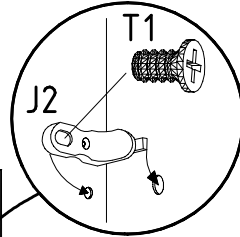
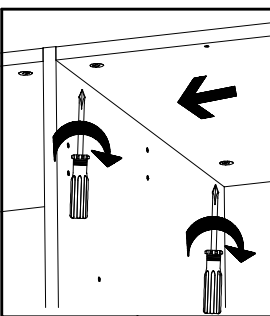
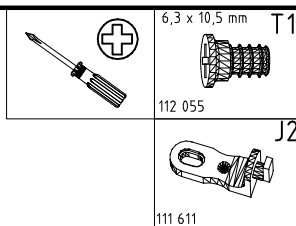

13

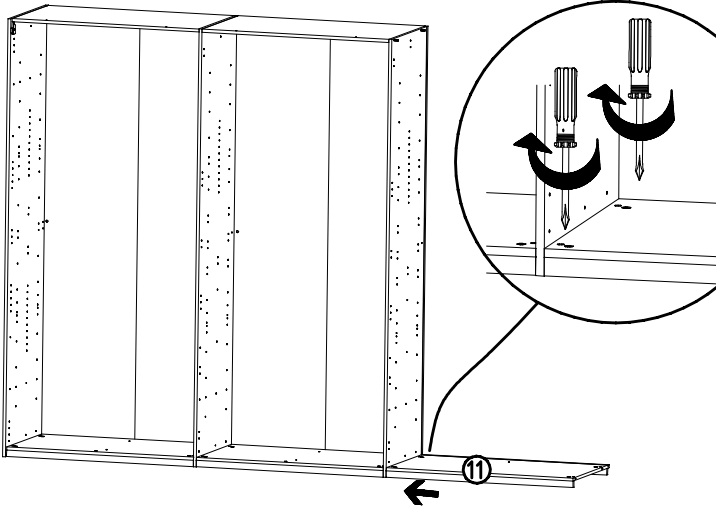
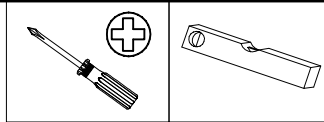
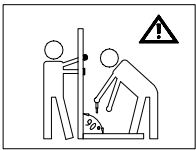

14

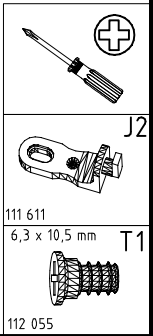
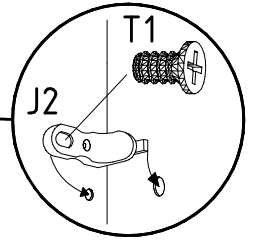
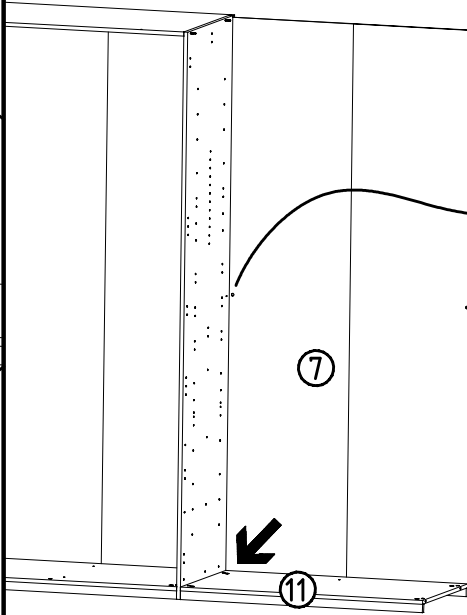

15

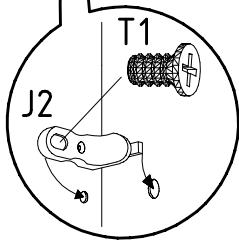
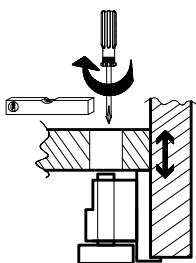
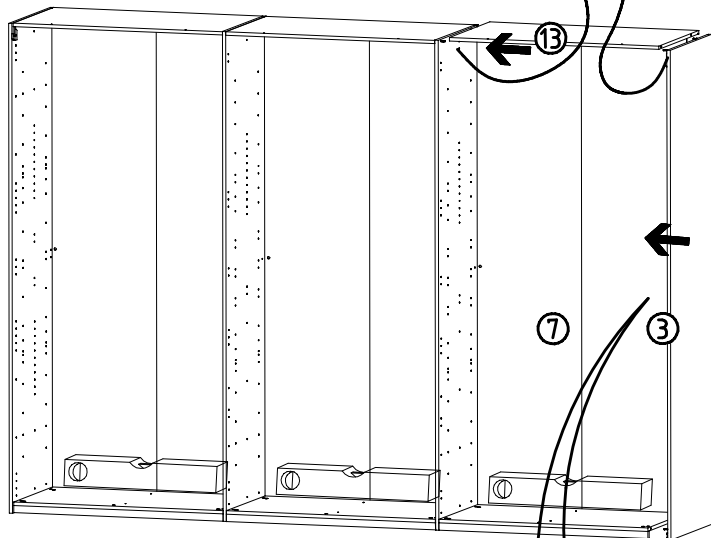
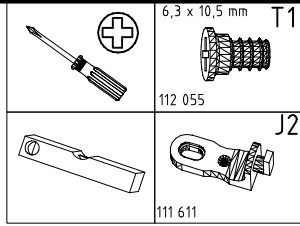
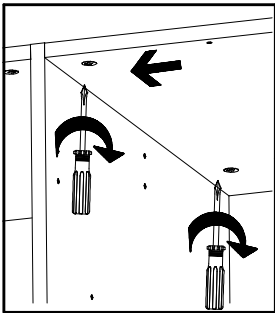

16

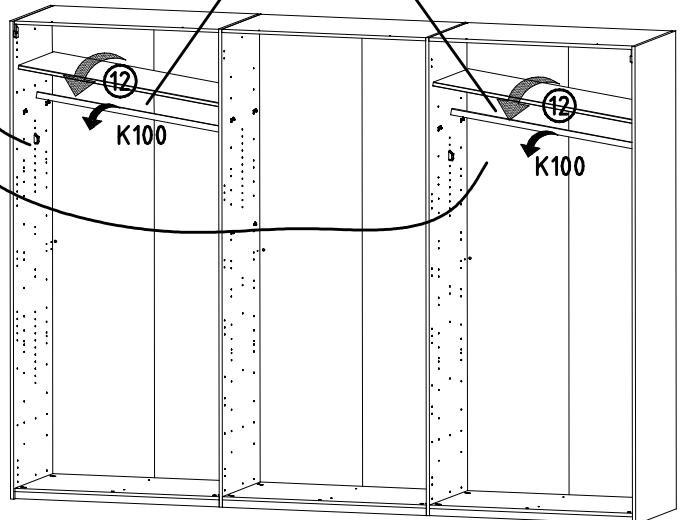
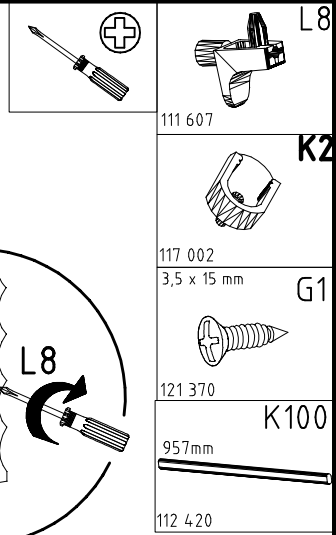
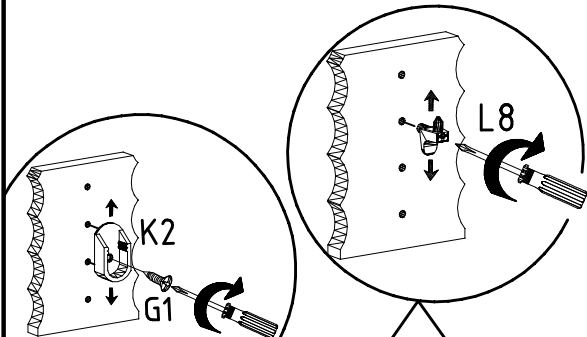

980747

12.07.24 / -

07 24|10/32

17

2x

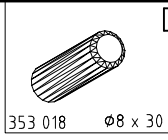
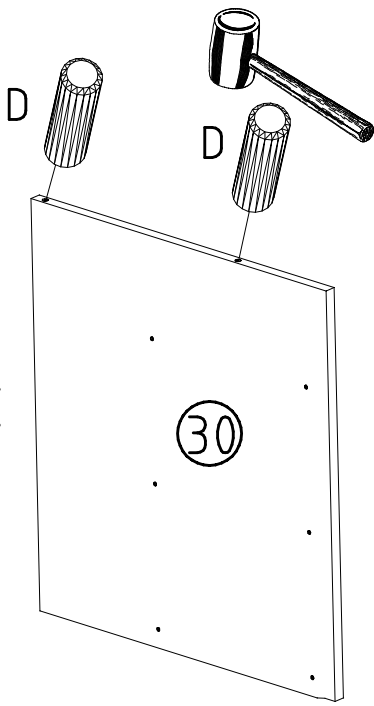

19

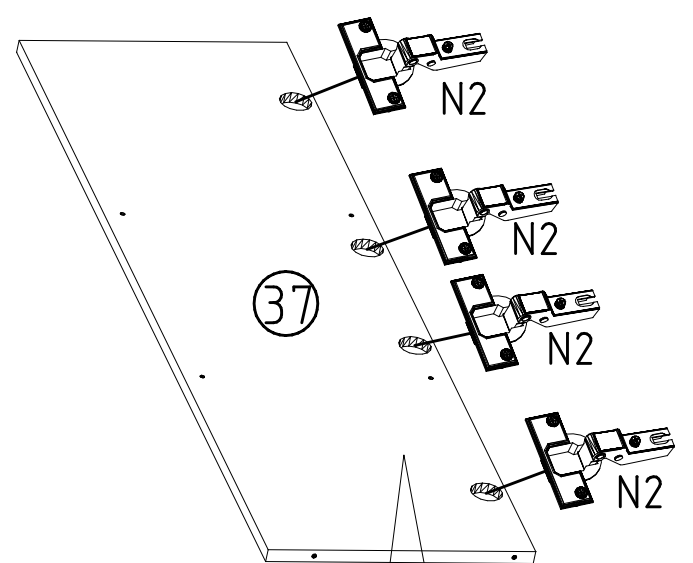
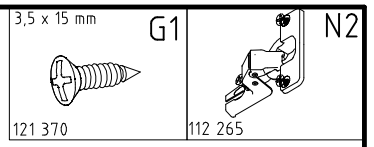

18

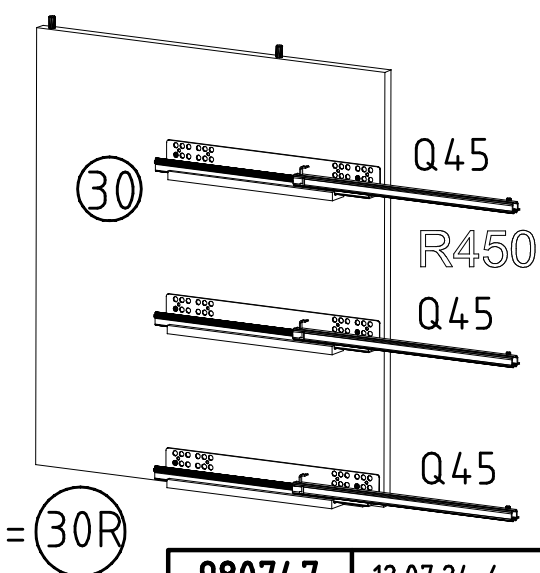
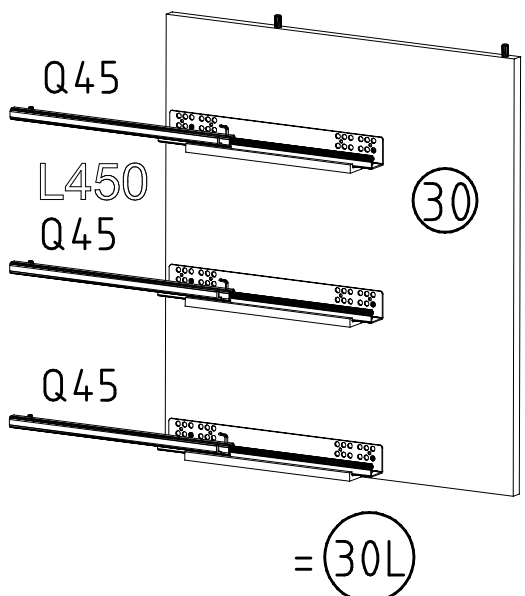
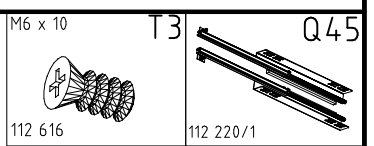
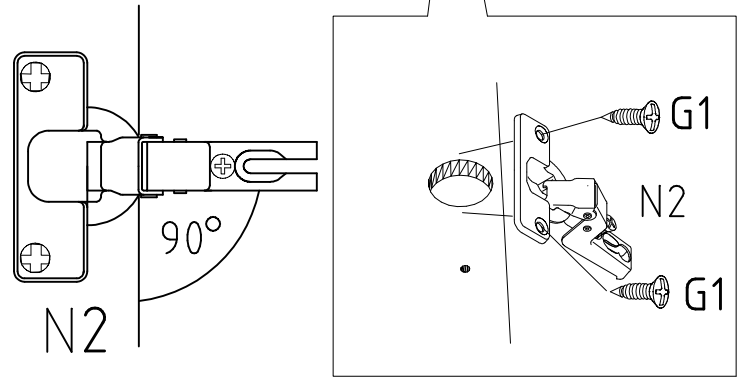
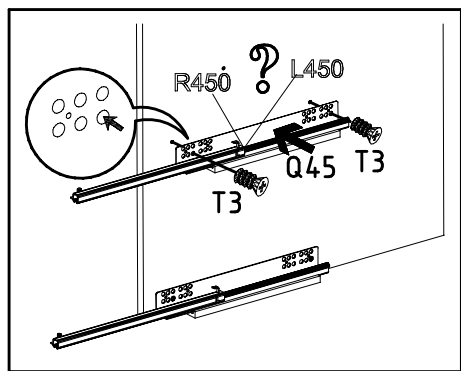

20

I.

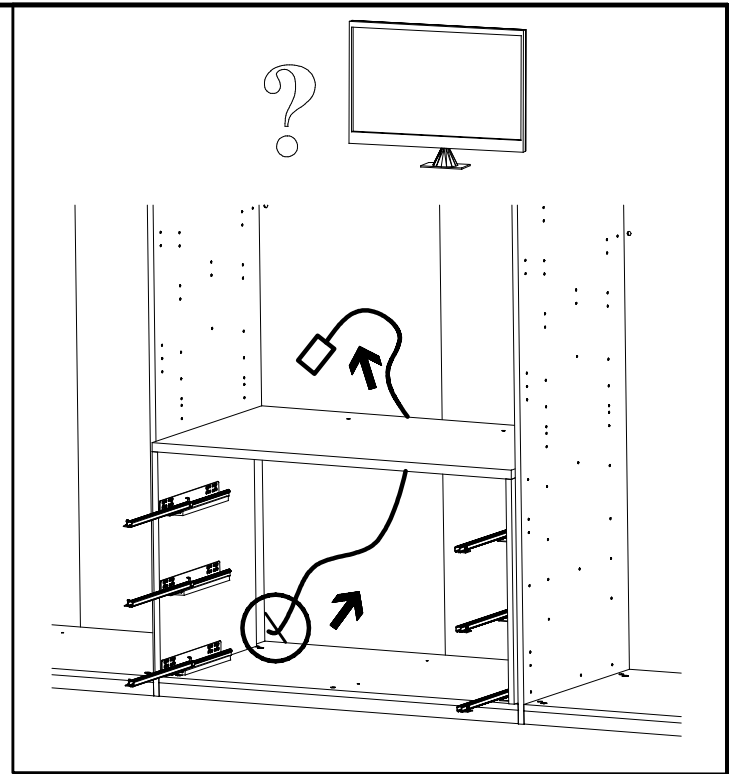
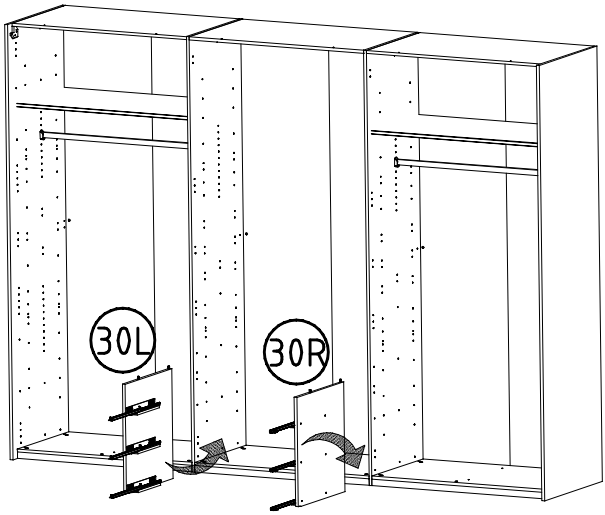

II.

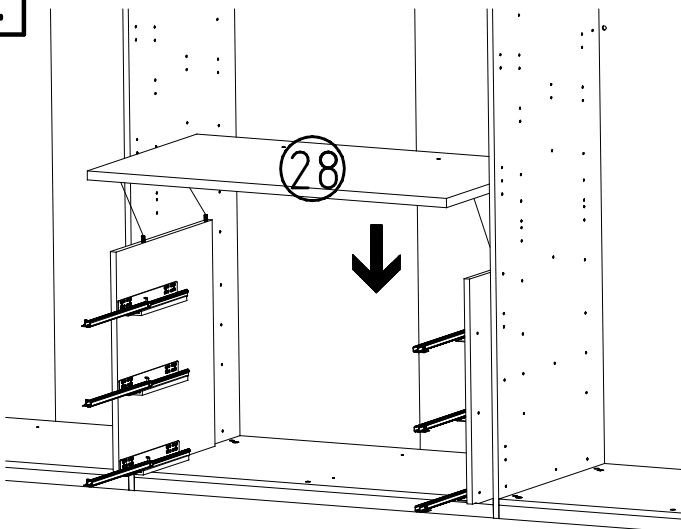

III.

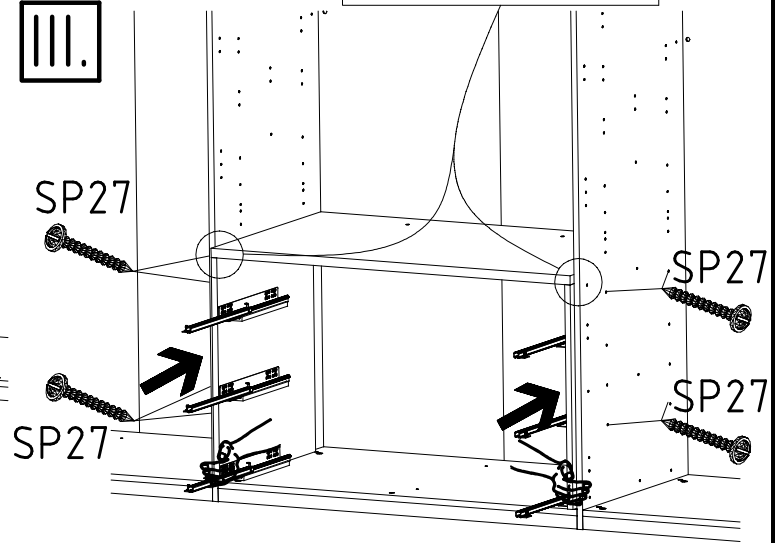

21

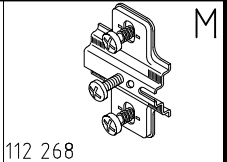
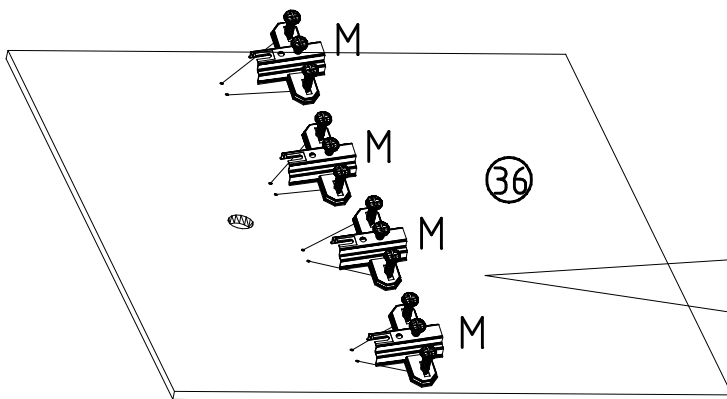

112 268

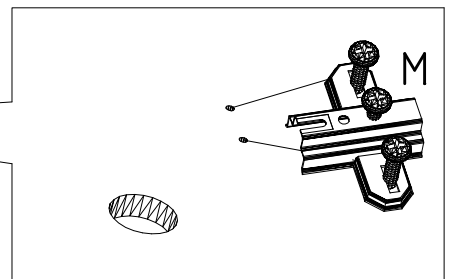

22

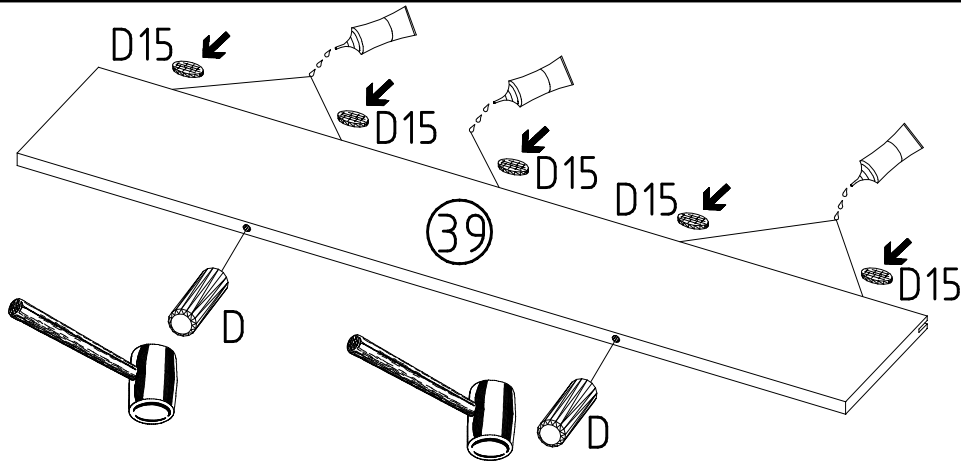

D15

353 020

Z

163 007

D

353 018    Ø8 x 30

23

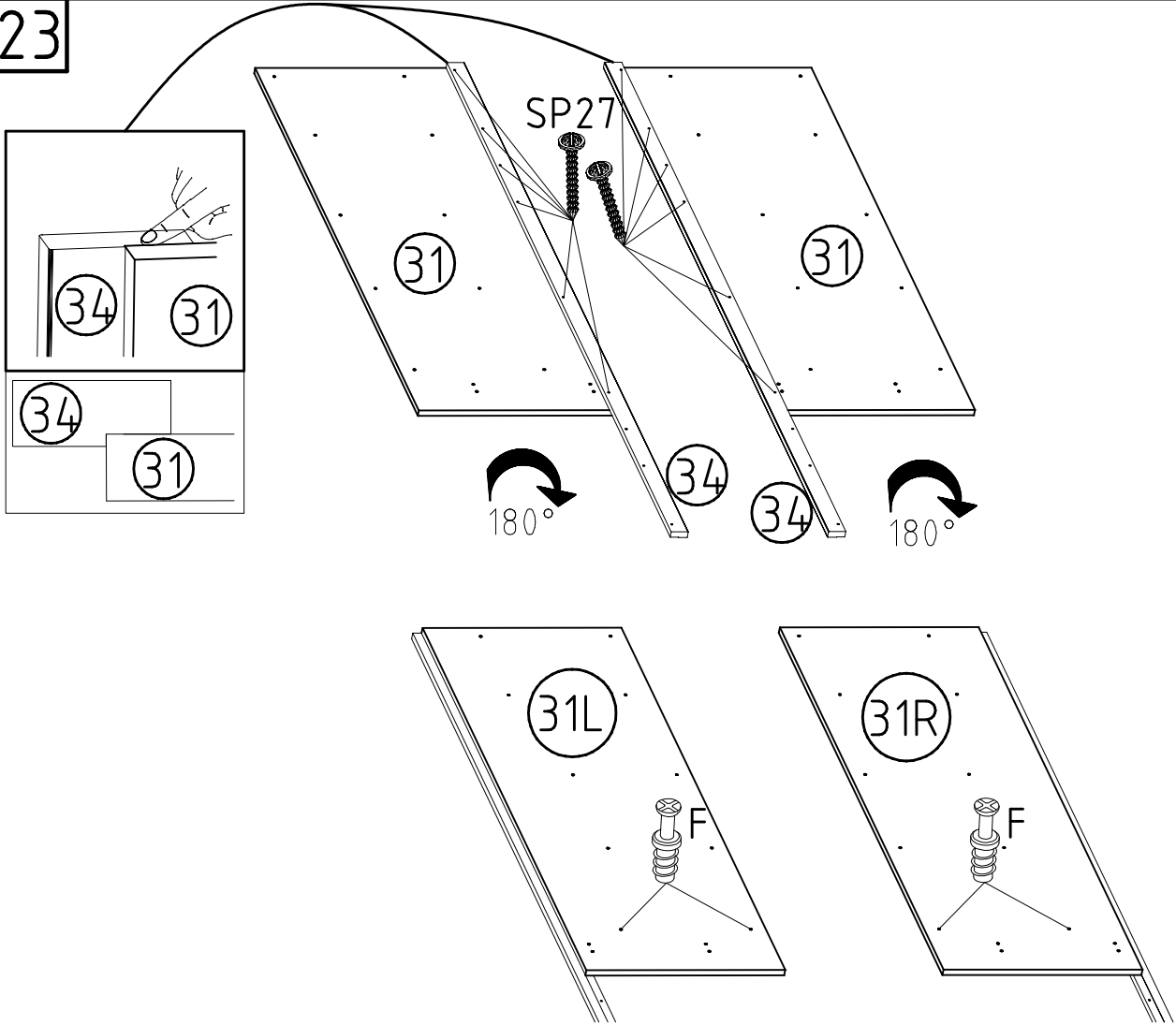

SP27

4 X 27mm

122620

F

111 229

24

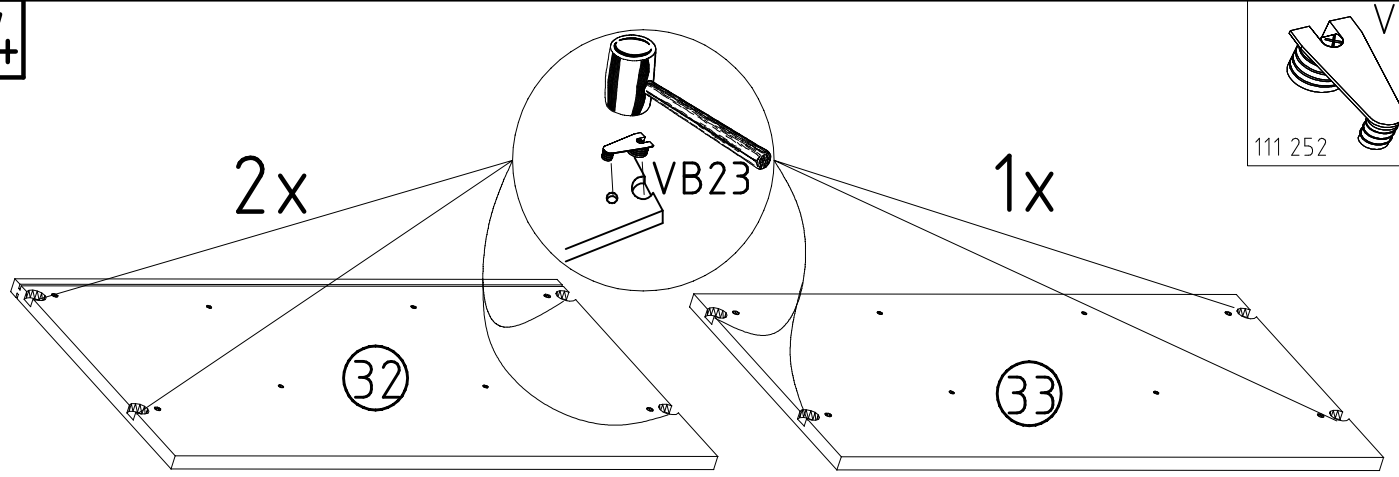

VB23

111 252

25

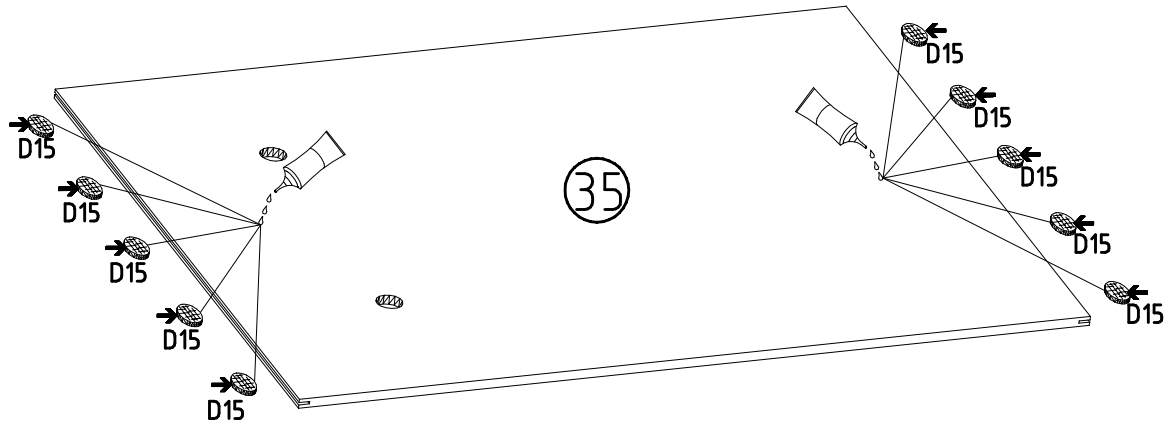

D15

353 020

Z

163 007

26

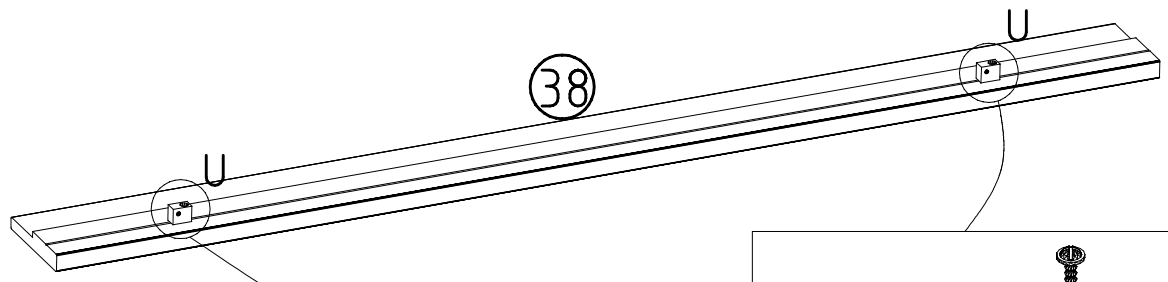

111 066/074

4 X 23 mm SP23

121117

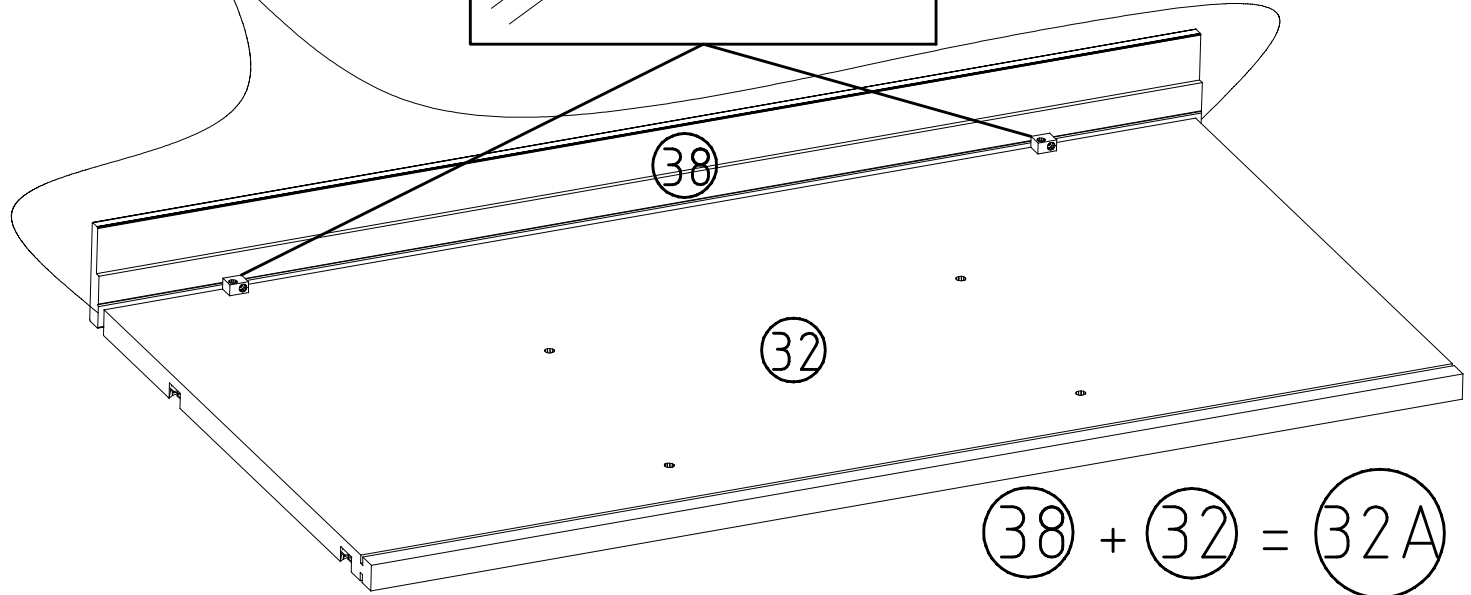
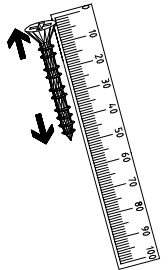
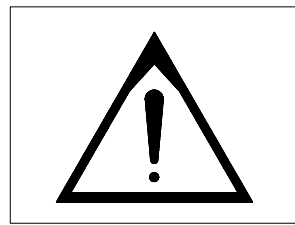
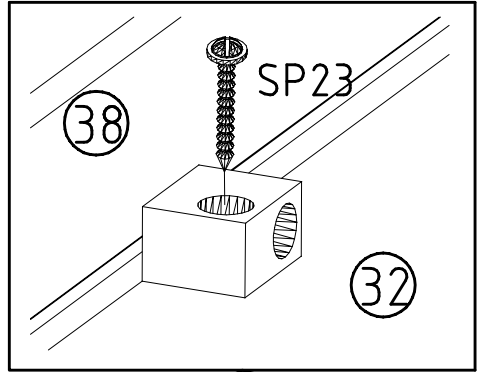
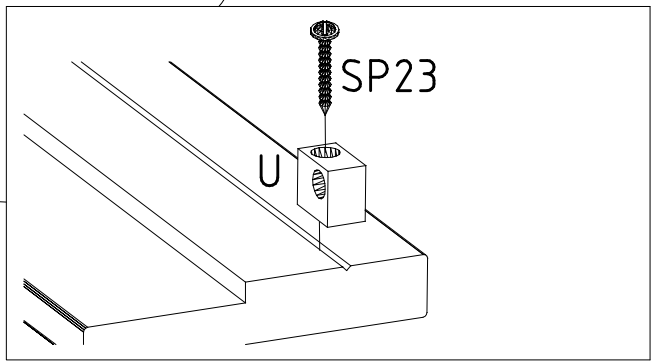
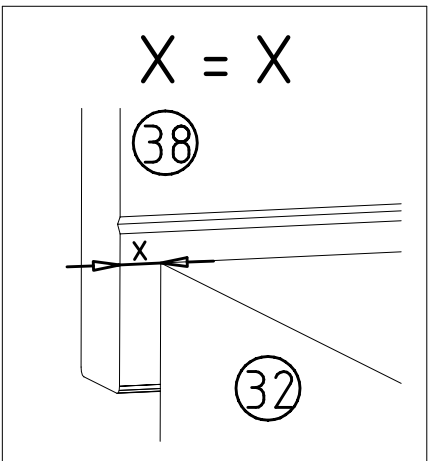

27

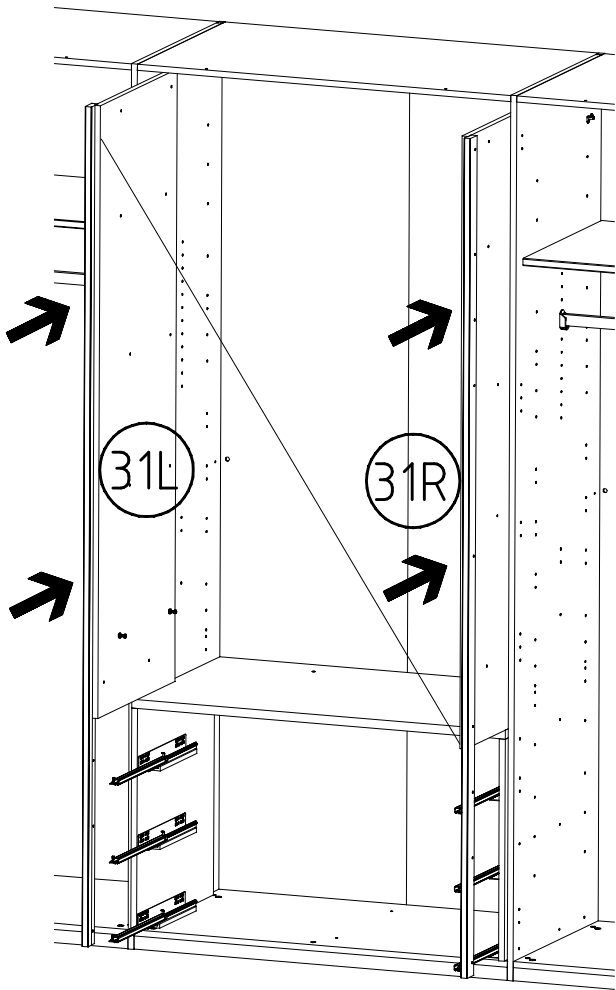

28

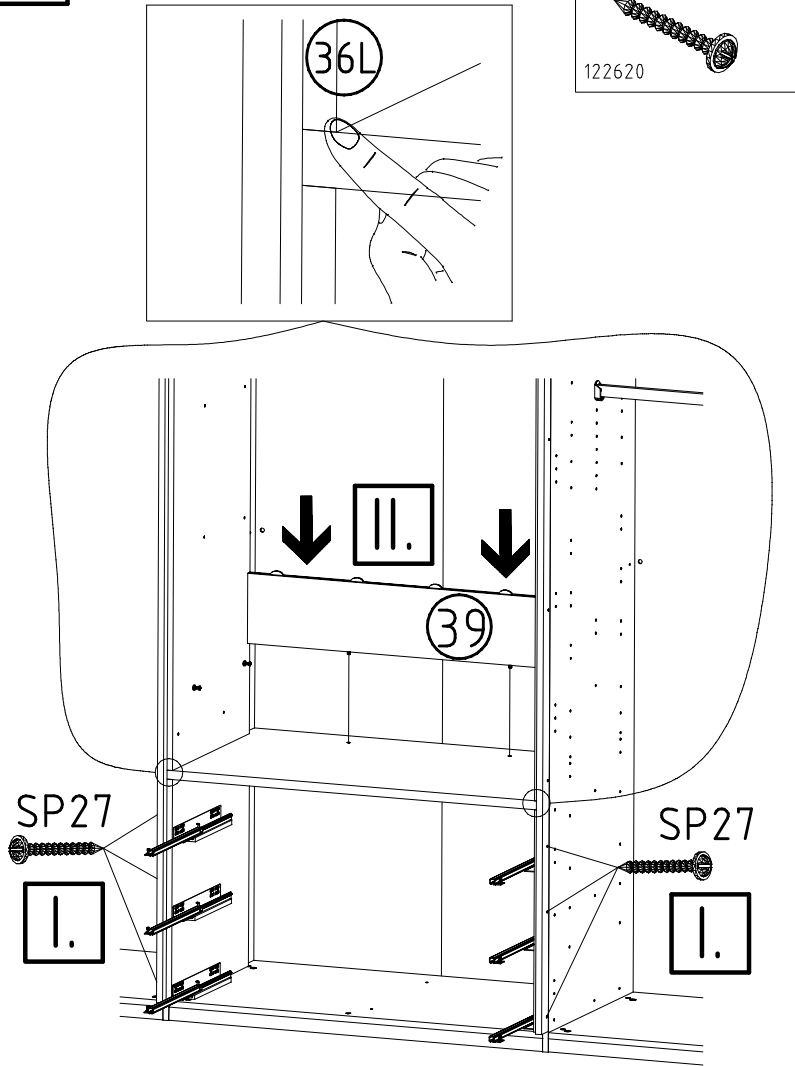

29

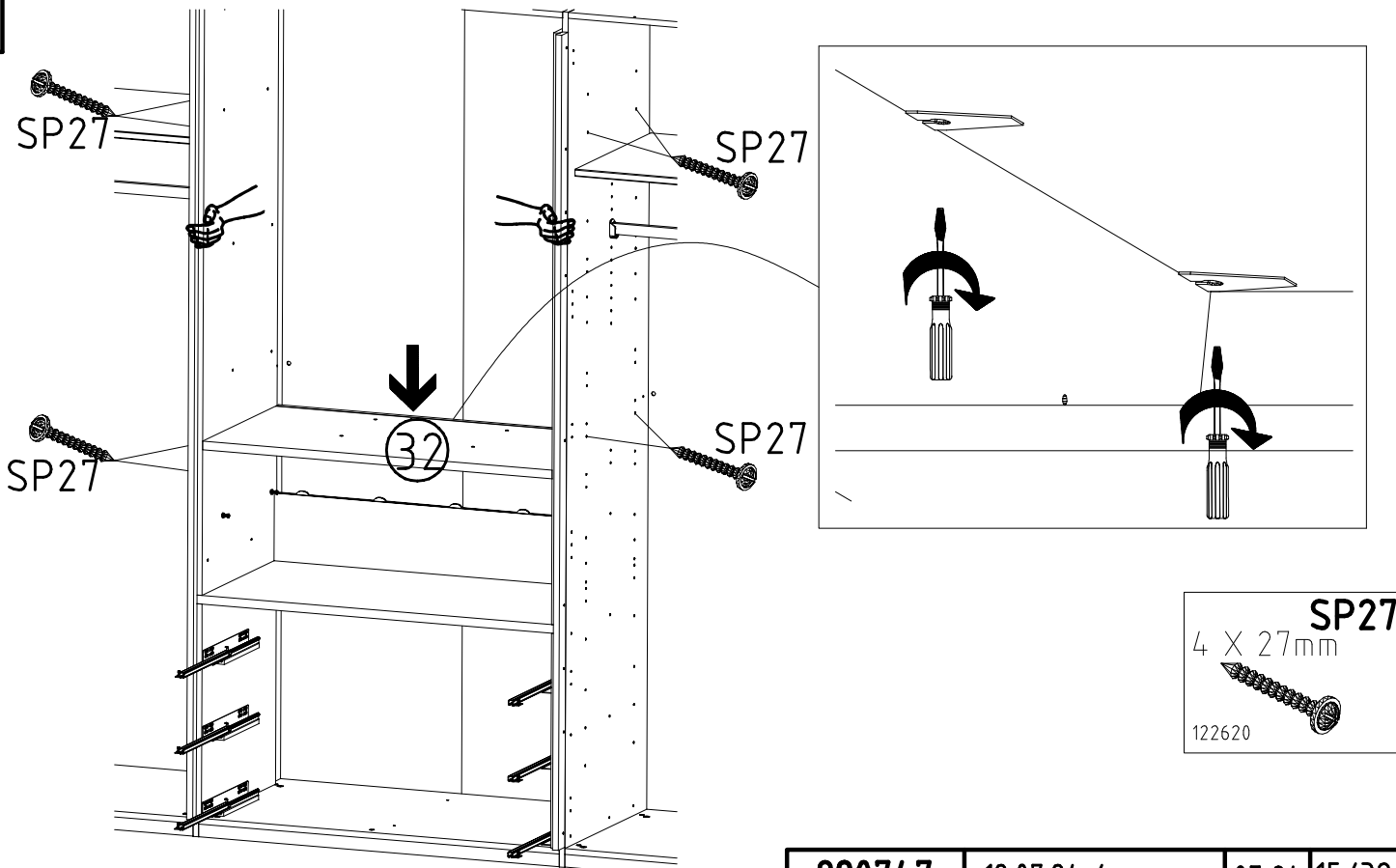

SW-LP L=2920 (1151/1769)	G43 M4x10	GH13 M4x13 PZ	M4 x 10 mm G43 121 xxx	M4 x 13 mm GH13 121 xxx
-----------------------------	--------------	------------------	---------------------------	----------------------------

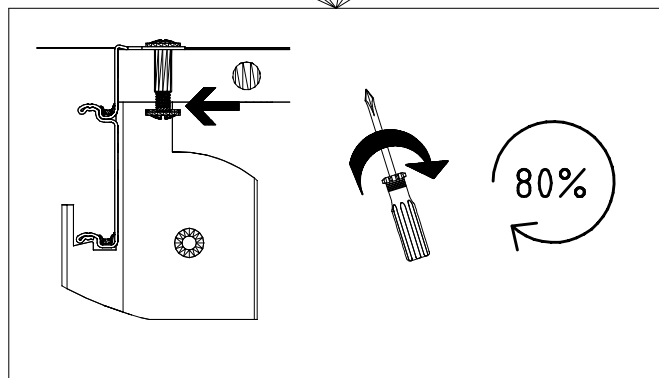
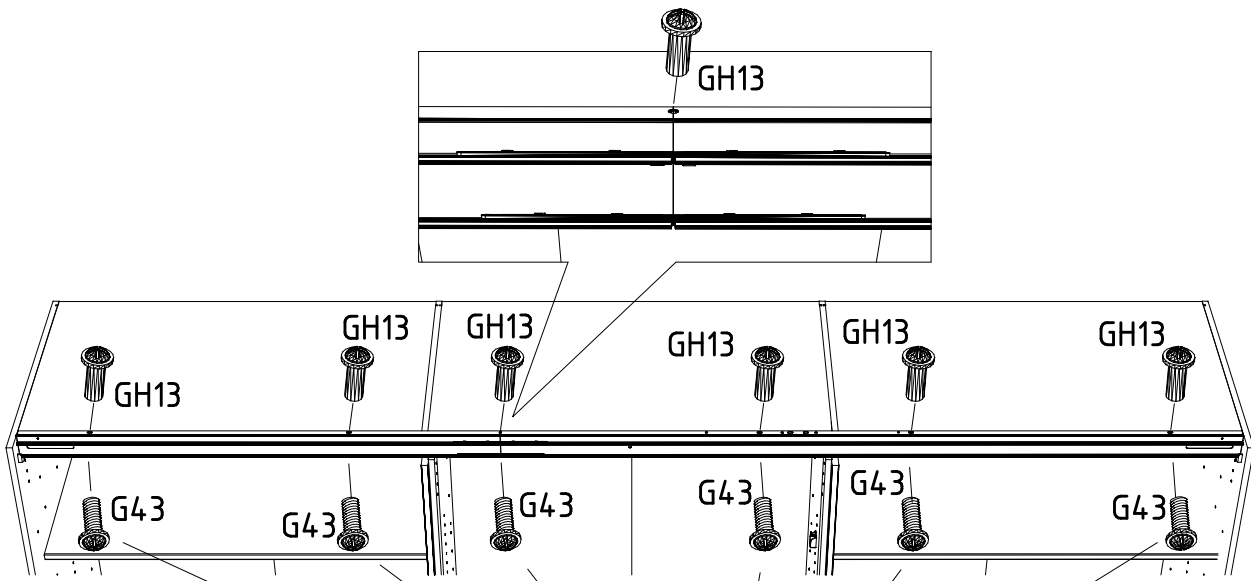
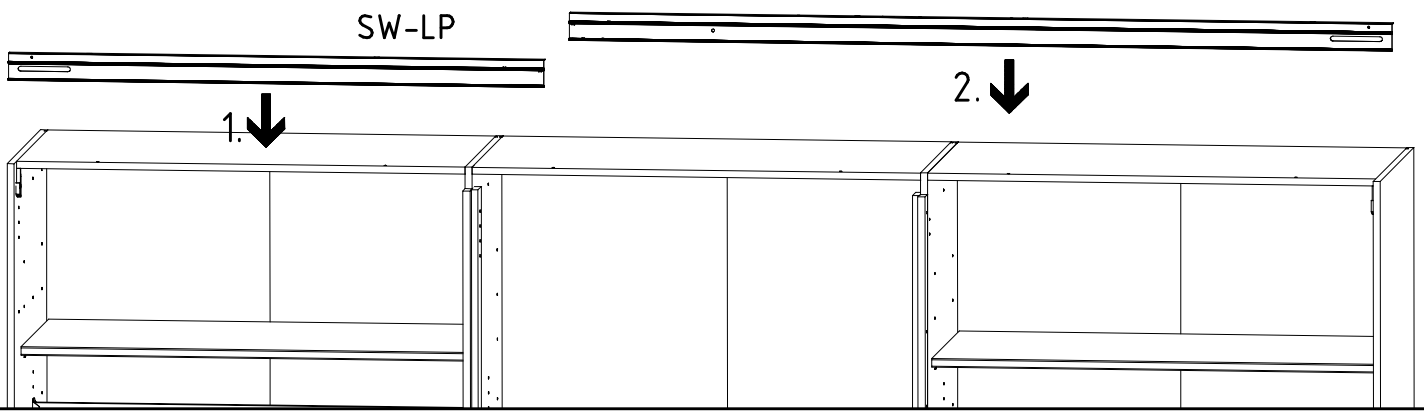

31

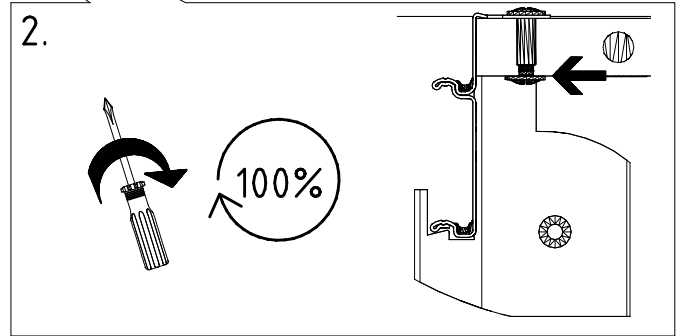
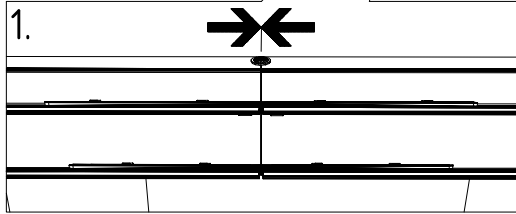
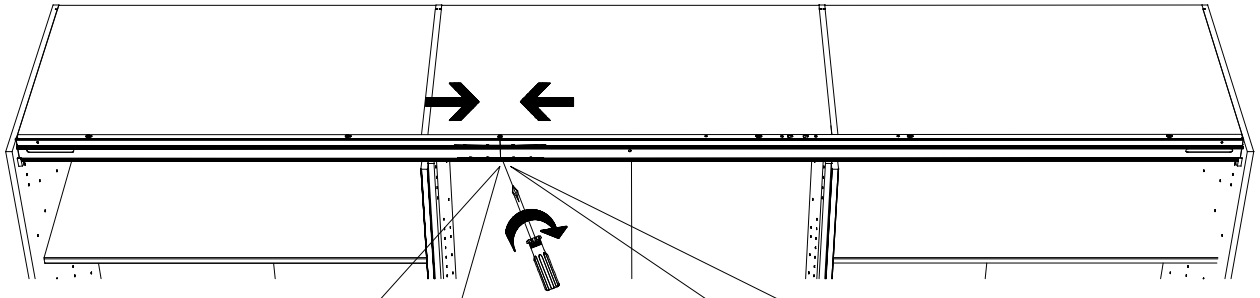

32

SW-VLP

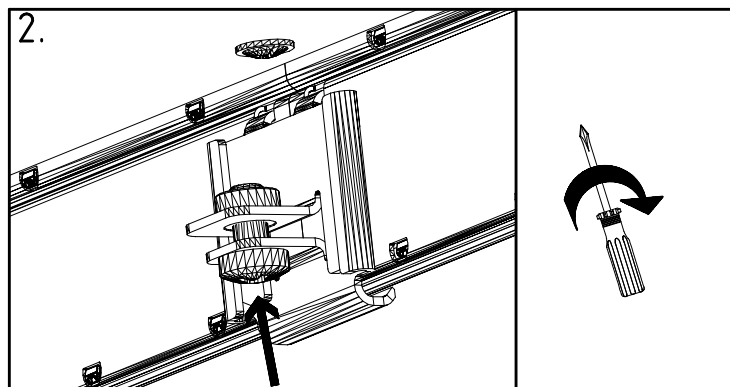
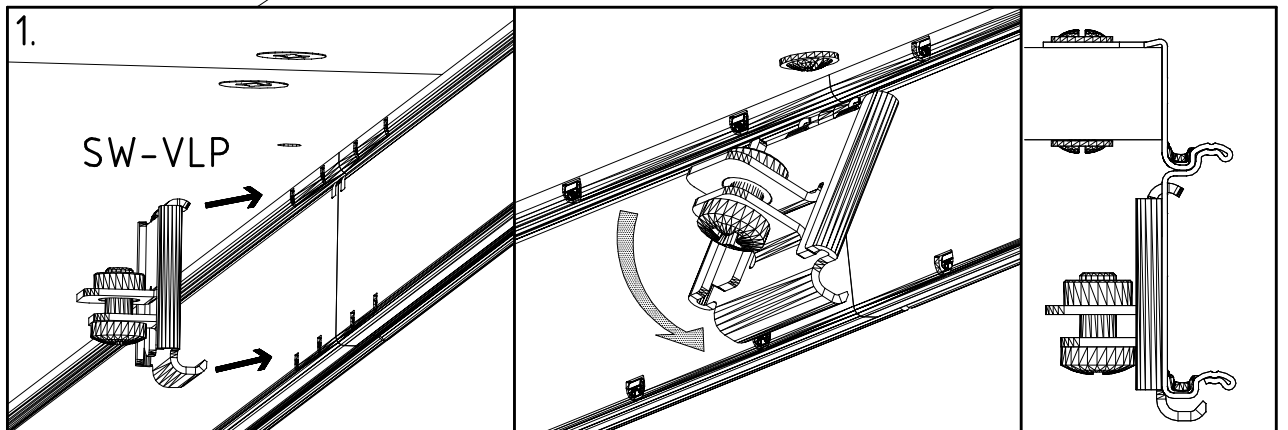
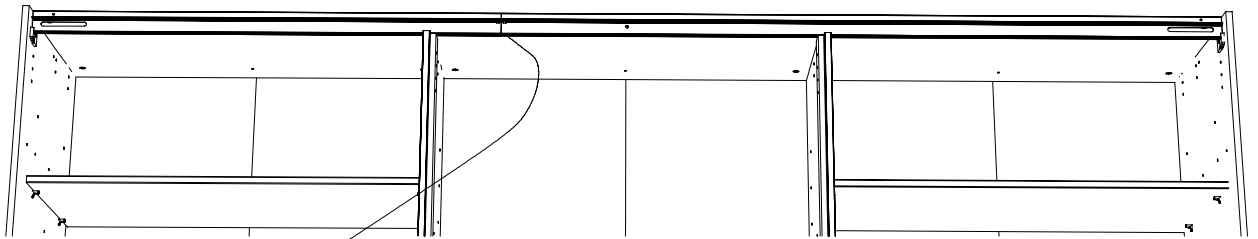

SW-M6x20



SW-STAS



SW-ST

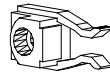

3,5x35 mm

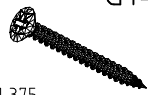

G14

121 375

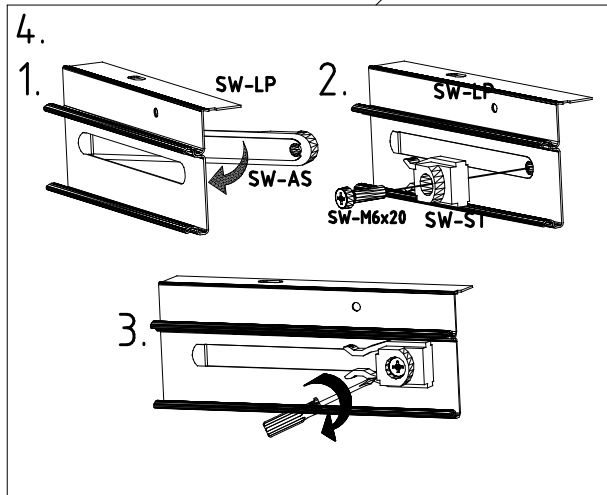
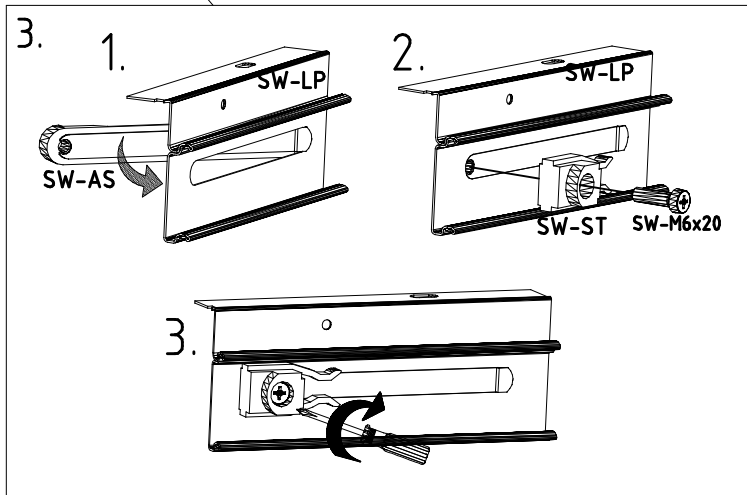
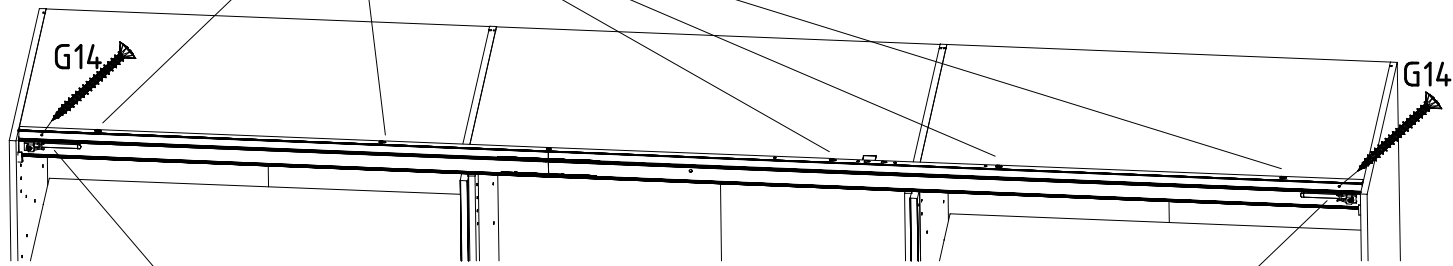
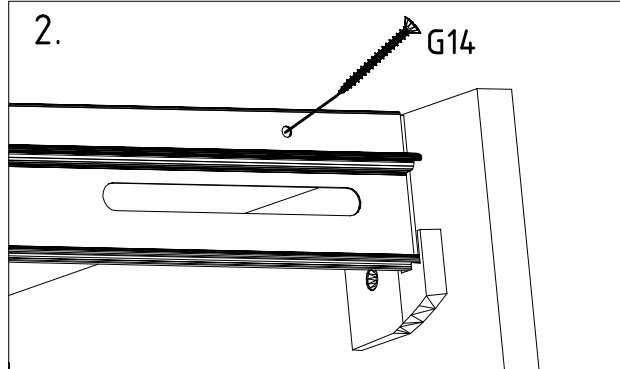
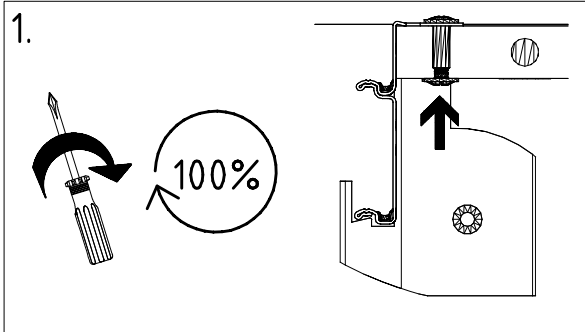

34

SP13  
4 X 13mm  
121 122

SW-SKM  

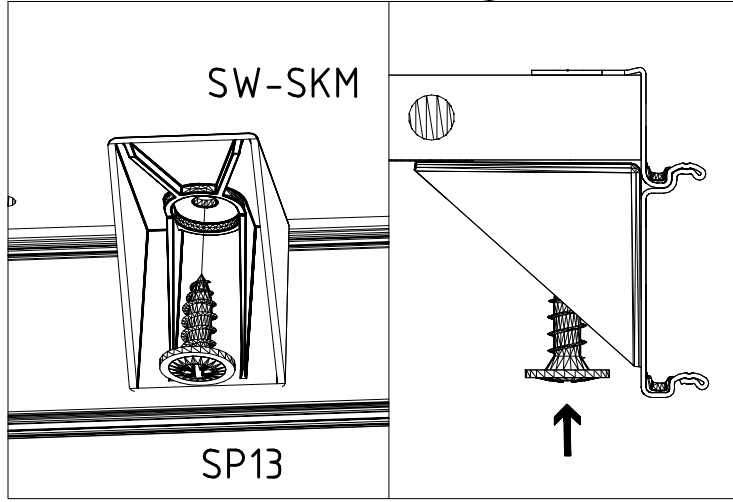
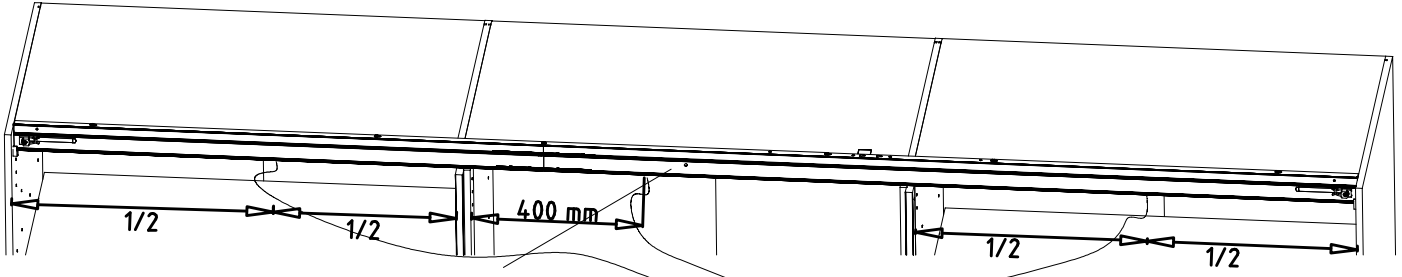



35

3,5 x 15 mm G1  
121 370

SW-FP  
L=1151 mm

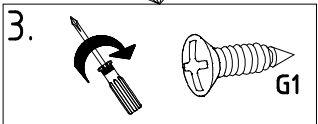
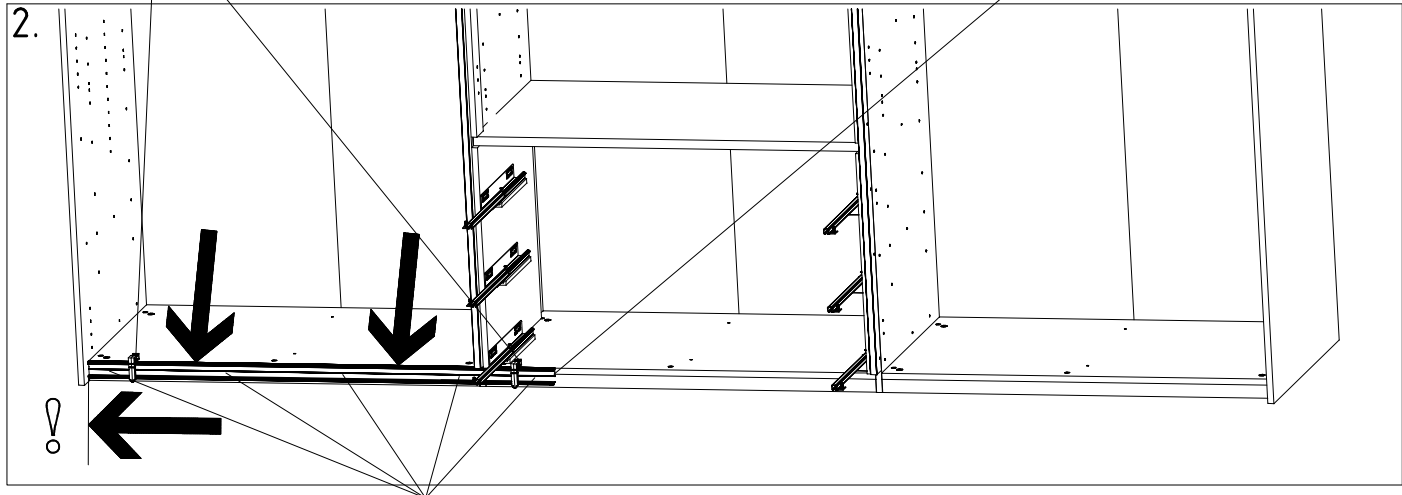
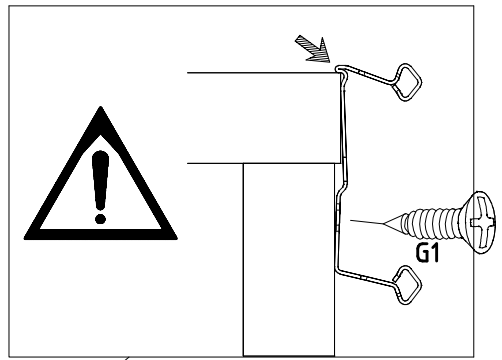
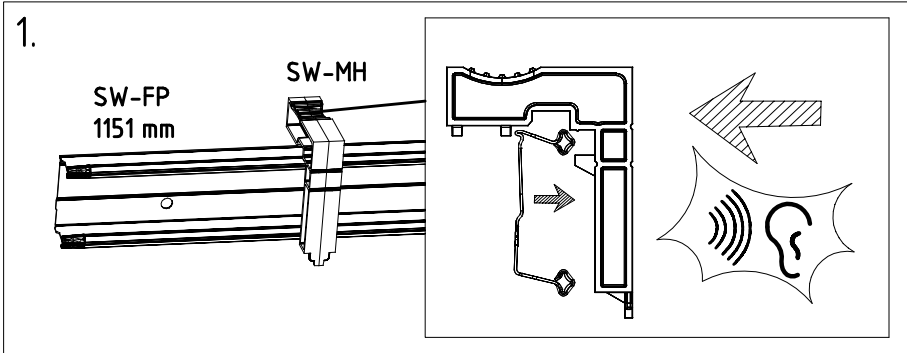
SW-MH  



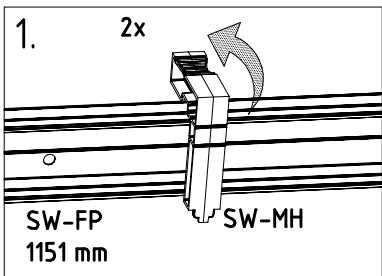

<p>SW-FP 3,5 x 15 mm G1 L=1769 mm</p>	<p>121 370</p>	<p>SW-MH</p>	<p>SW-VFP</p>
---	----------------	--------------	---------------

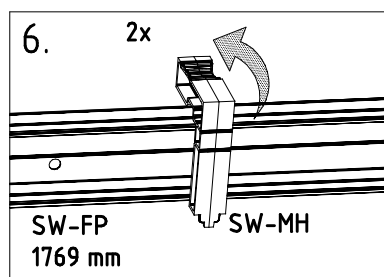
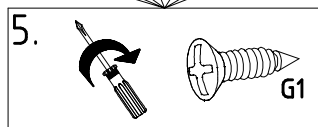
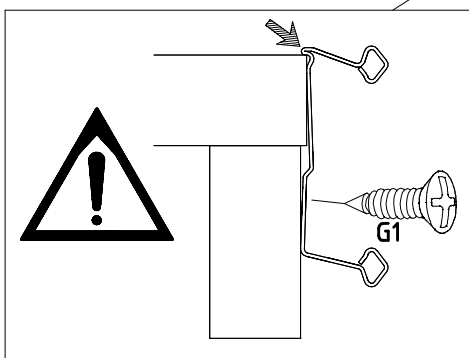
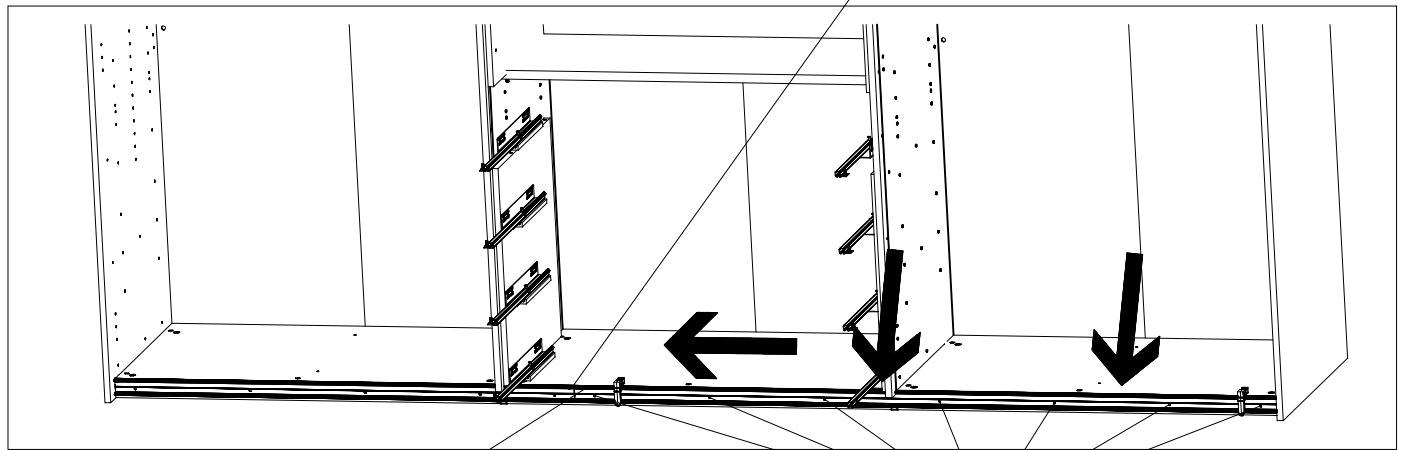
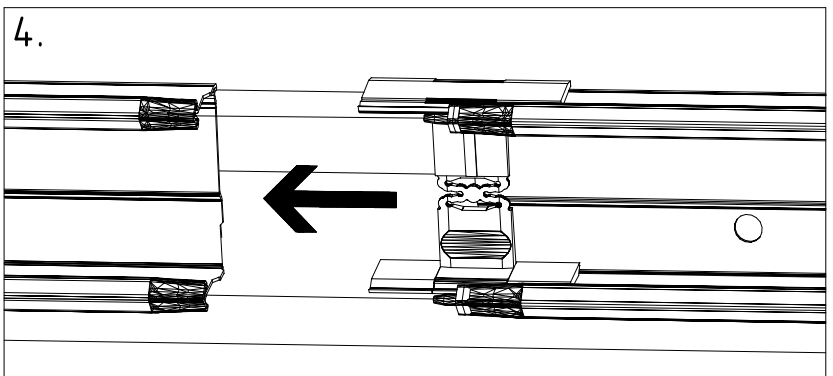
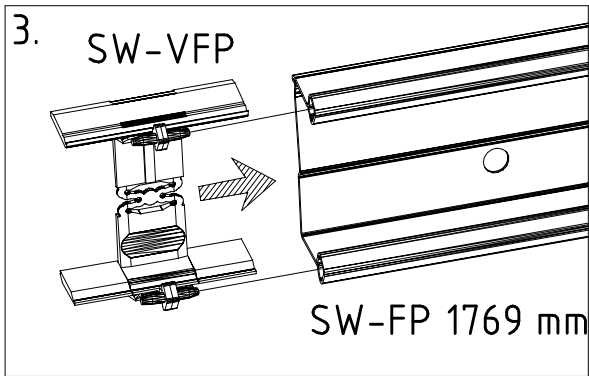
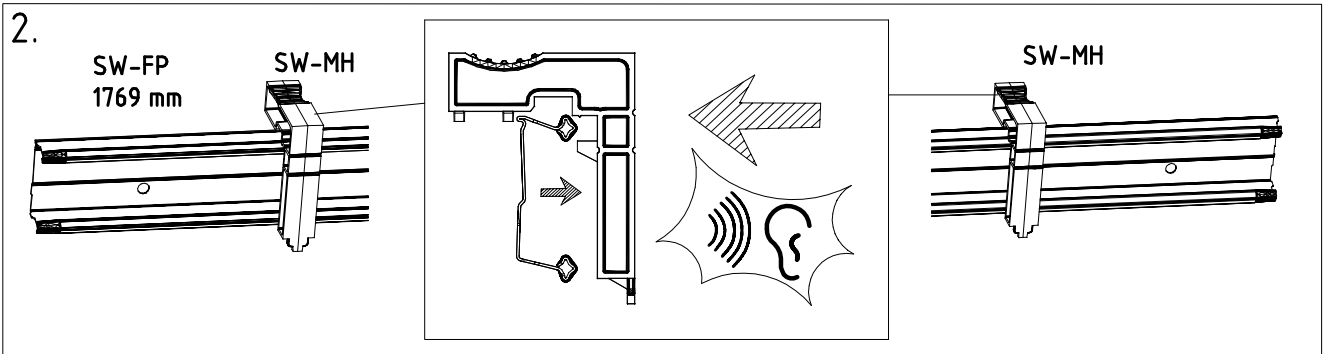

37

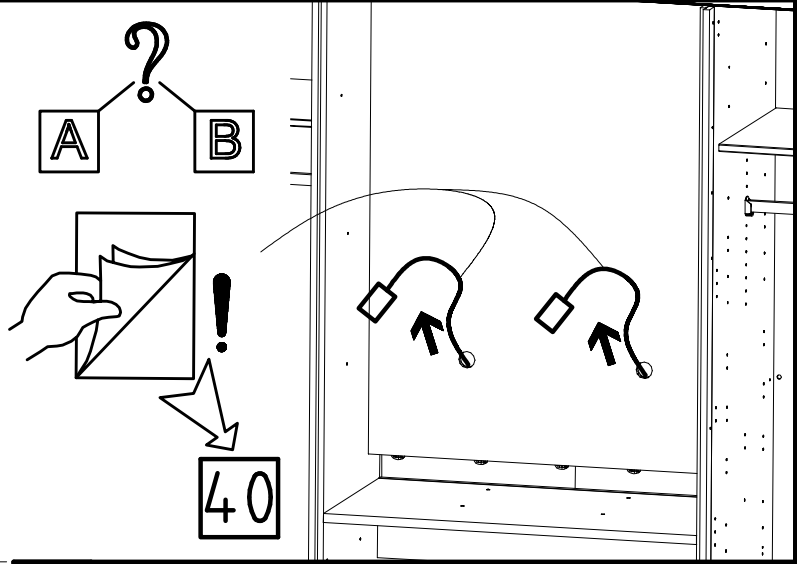
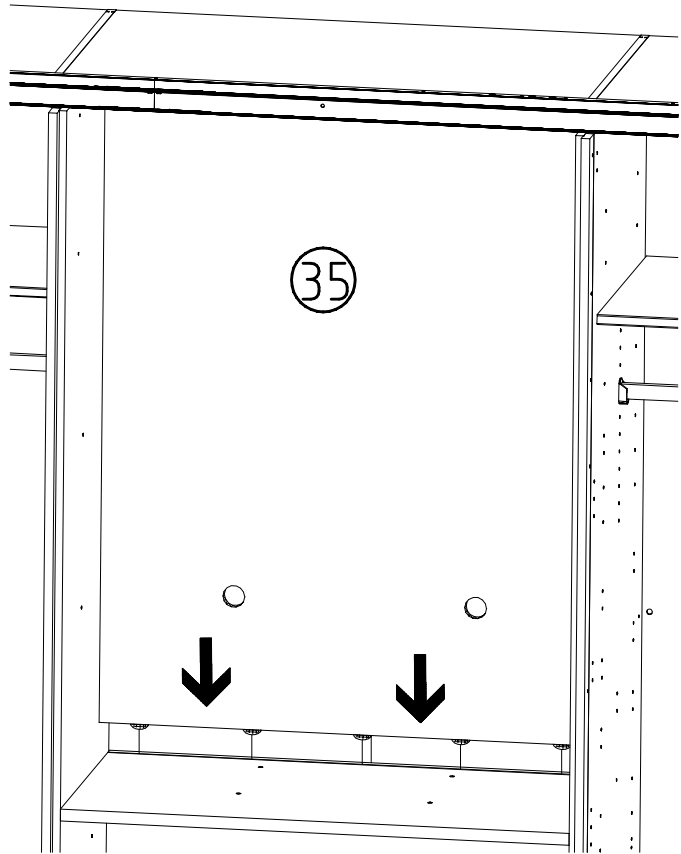

38

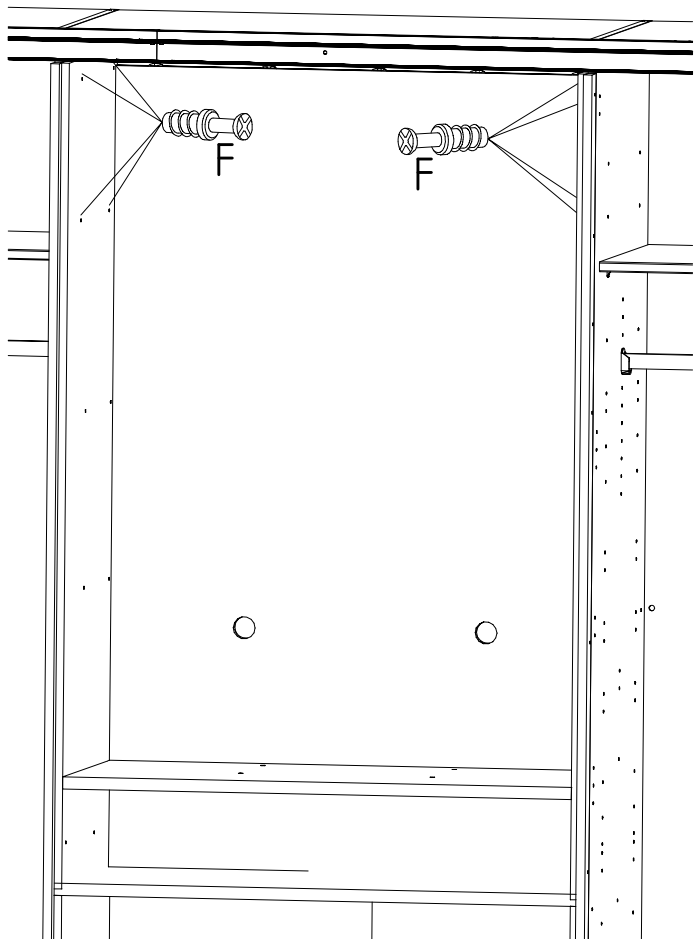
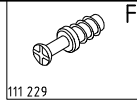

39

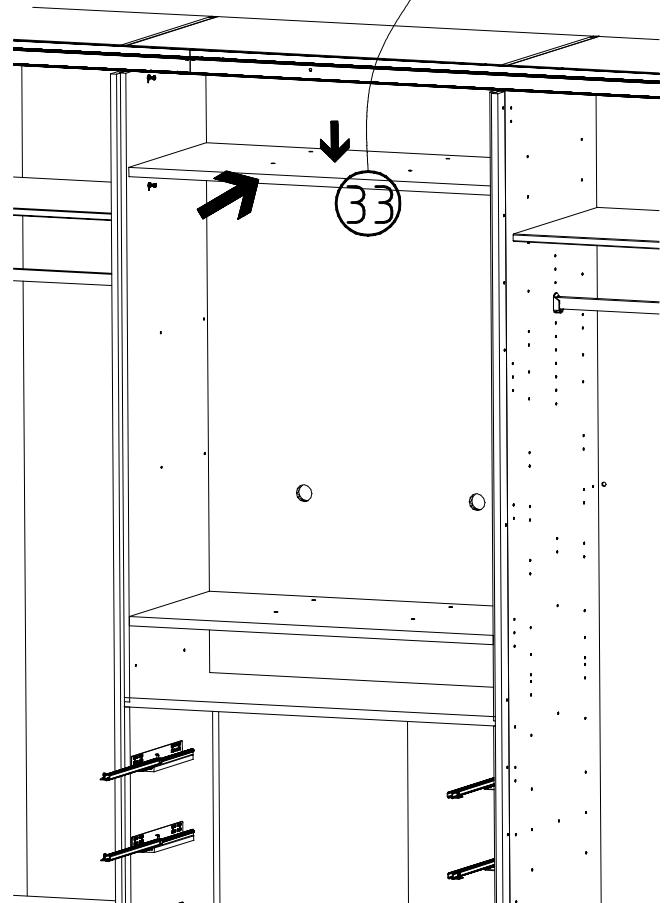
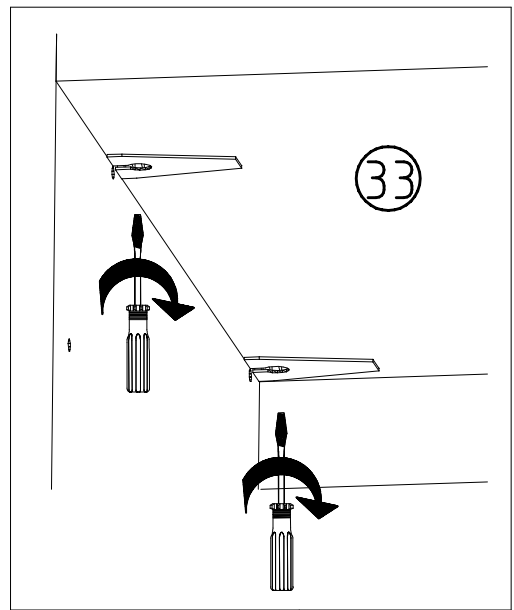

40

A

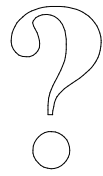

B

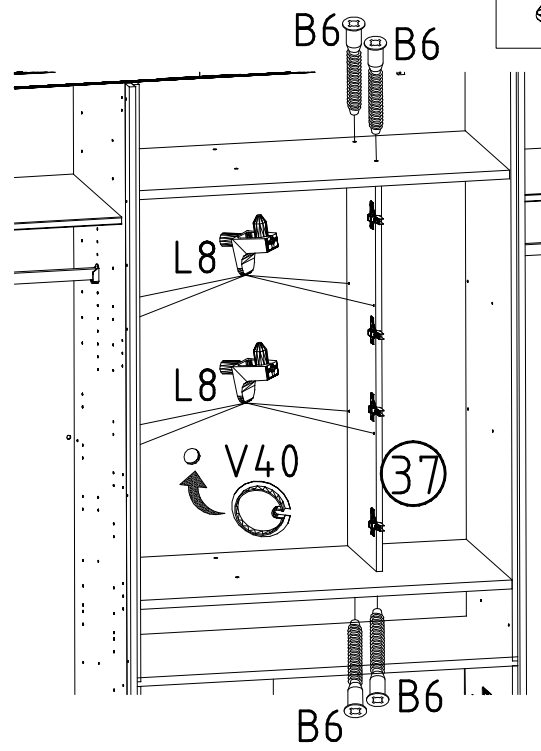
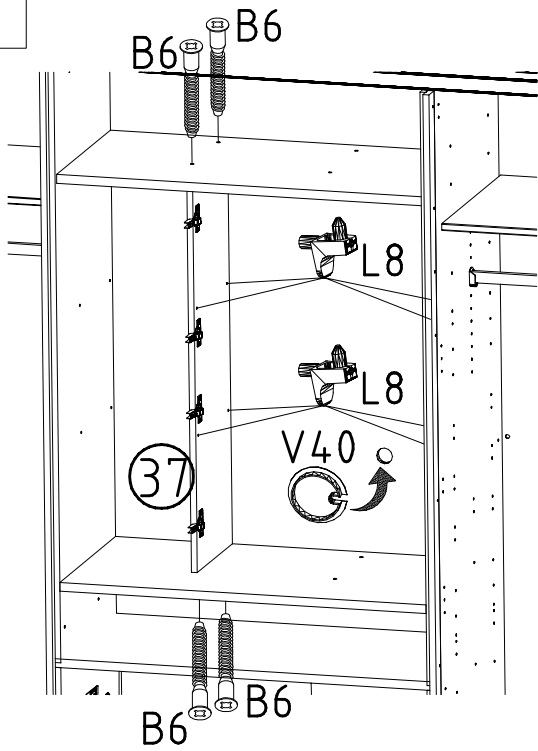
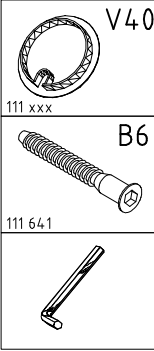
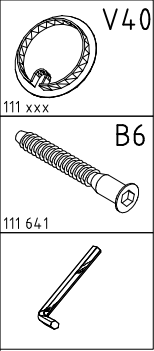
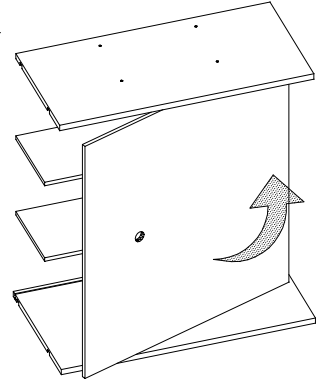
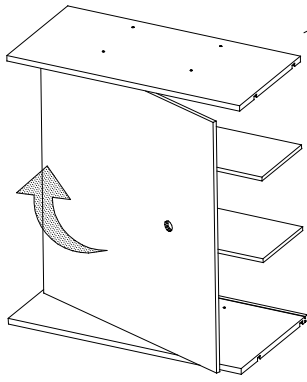

41

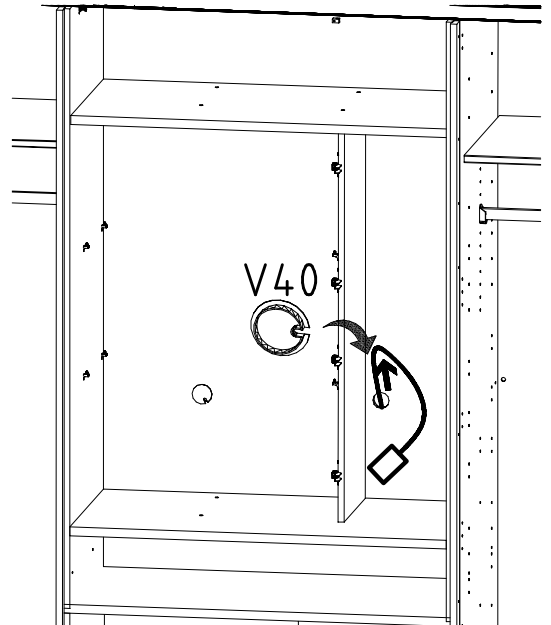
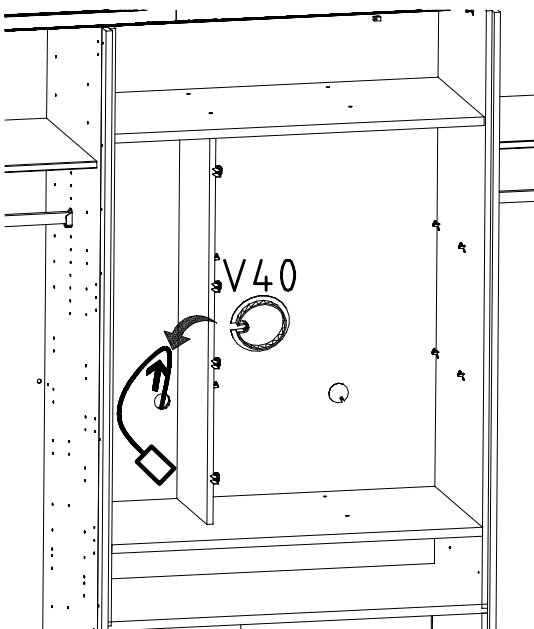
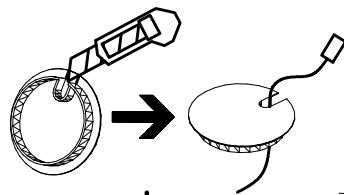

42

A

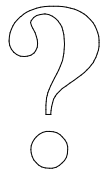

B

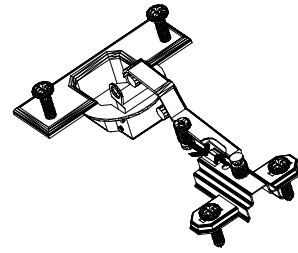
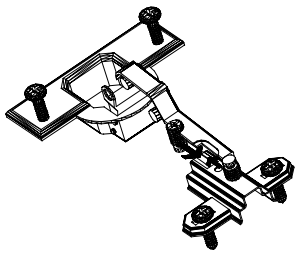
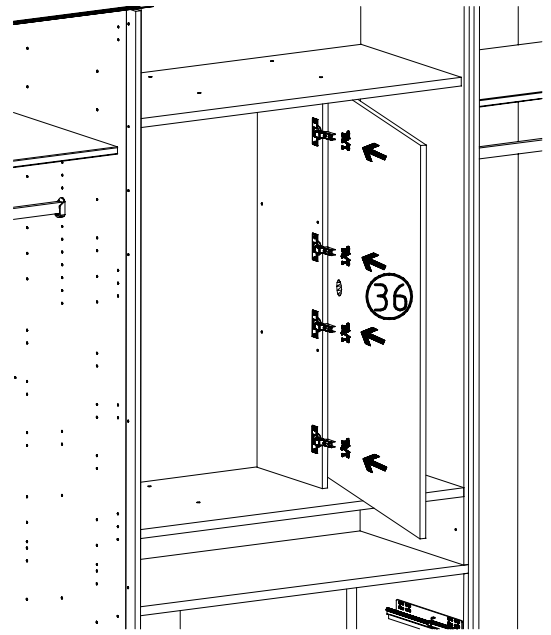
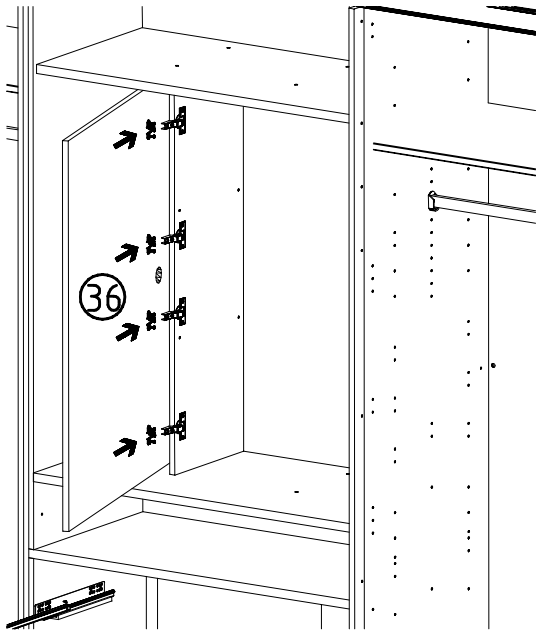

43

KP8

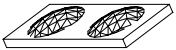

352 302

1

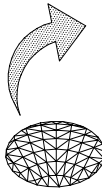

KP 8

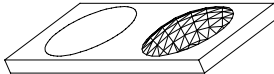

KP8

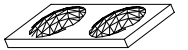

352 302

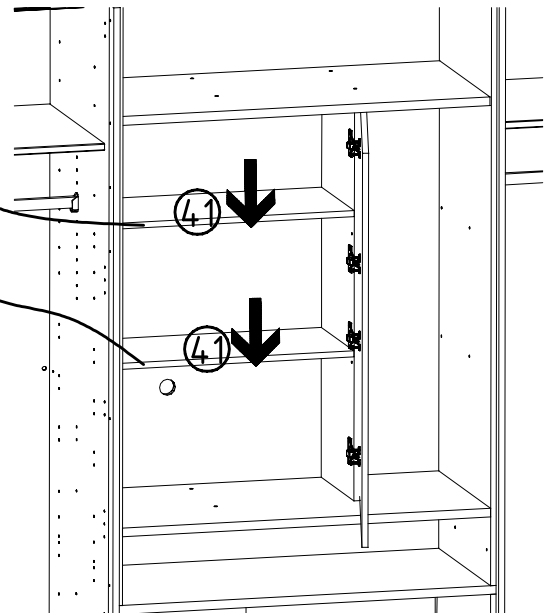
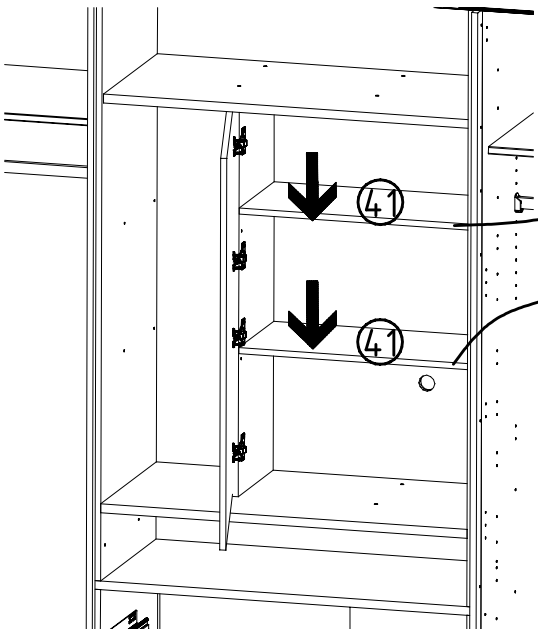

980747

12.07.24 / -

07 24 23/32

44

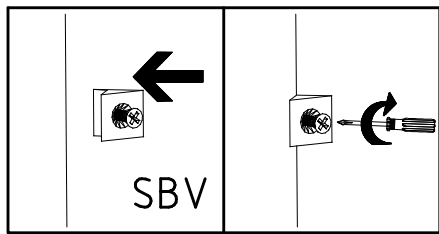

3,5 x 15 mm

G1



121 370



SBV

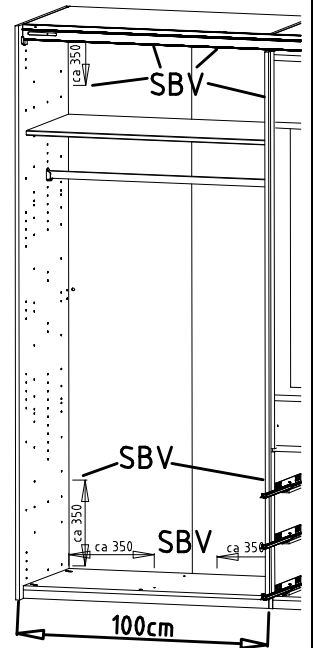
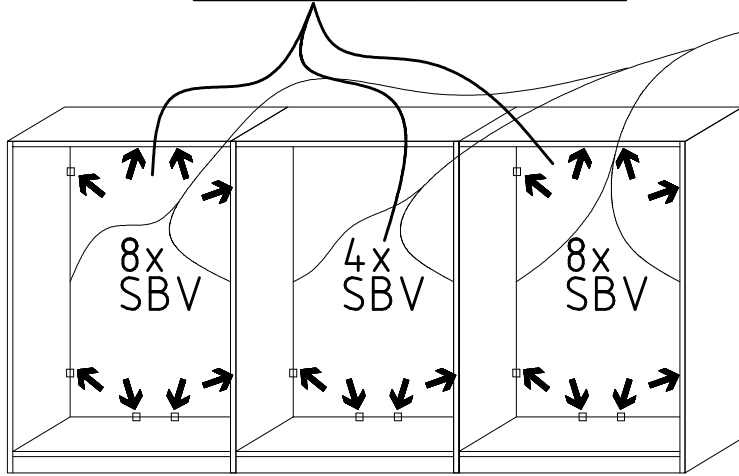
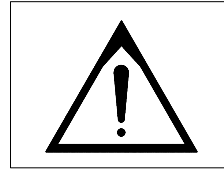
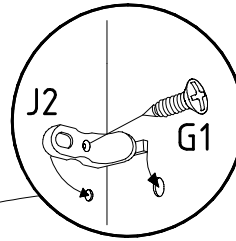

45

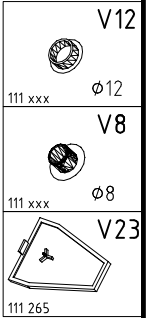
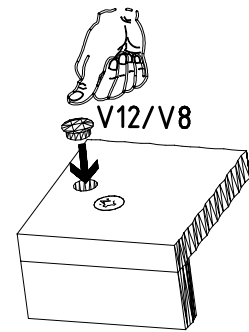
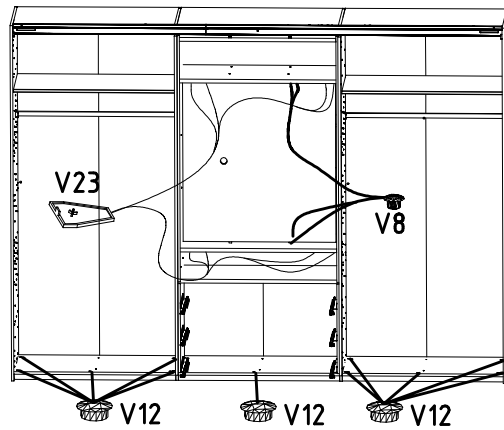

46

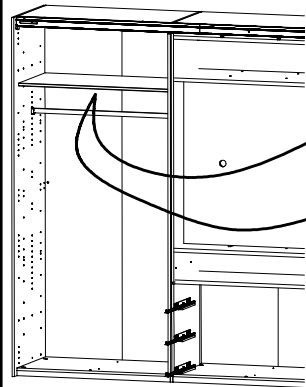
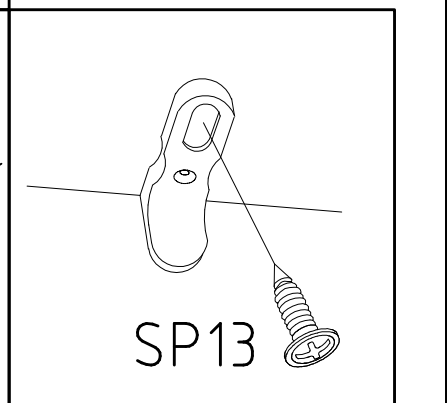
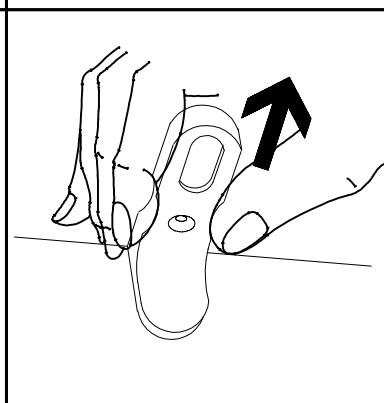
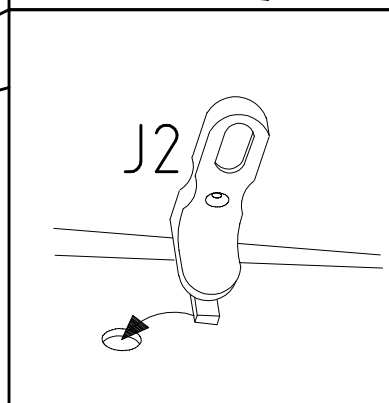
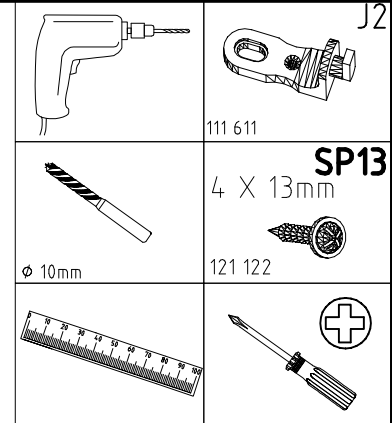
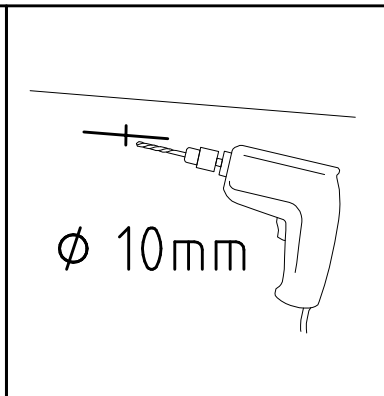
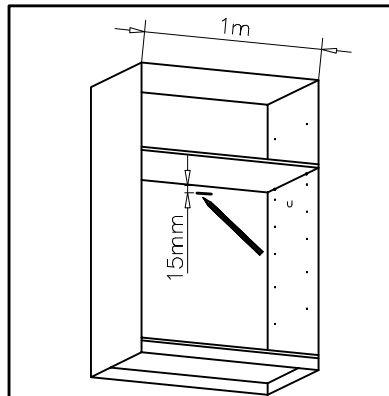

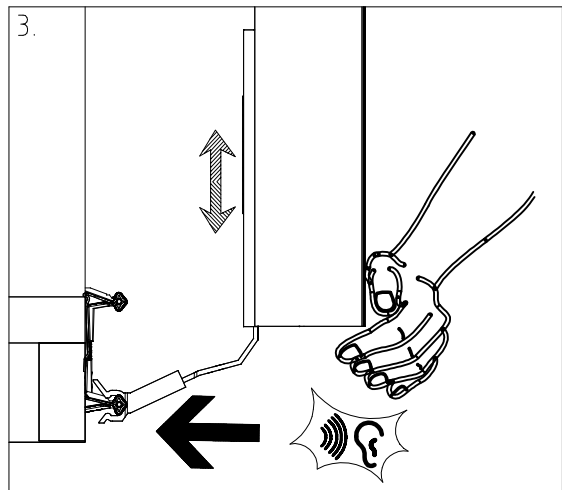
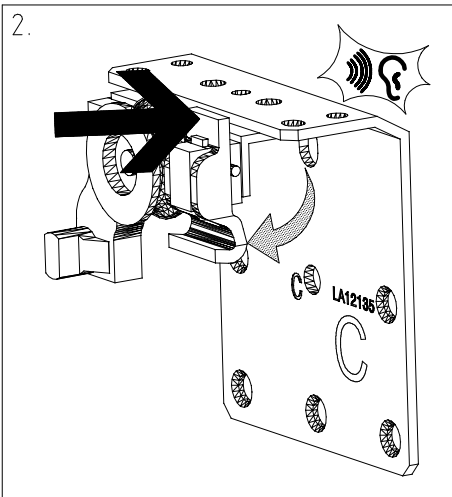
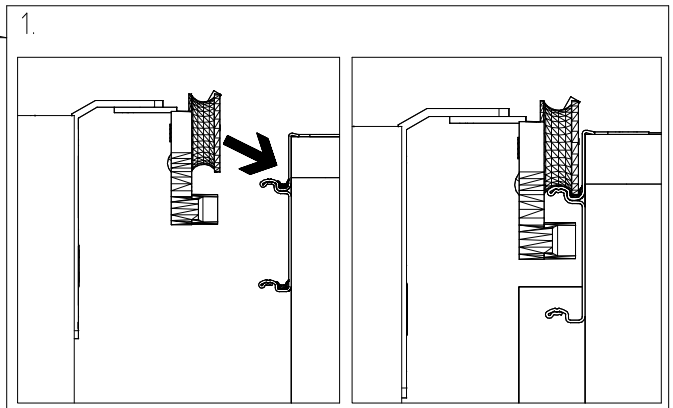
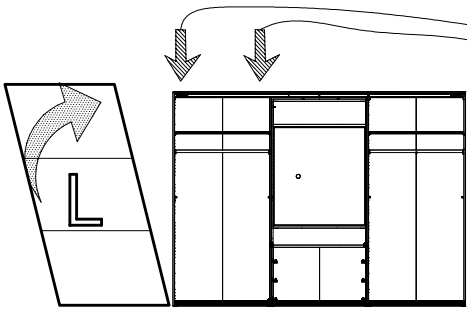
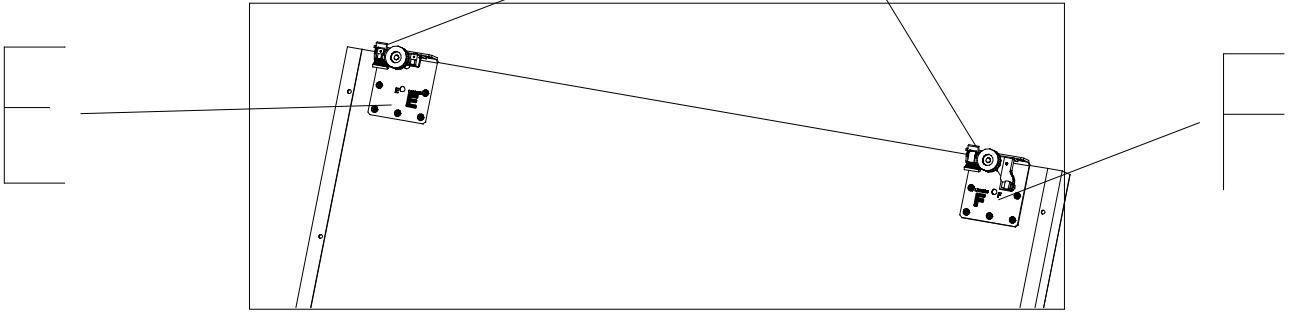
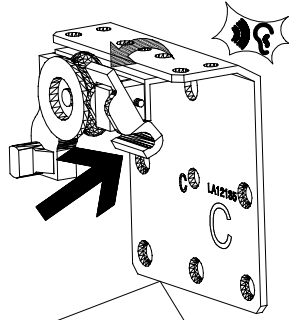
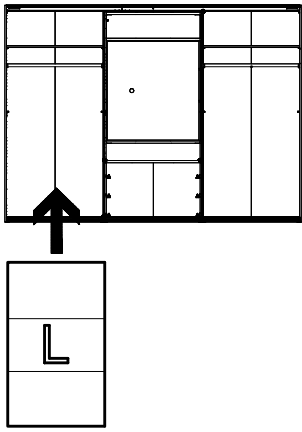

47

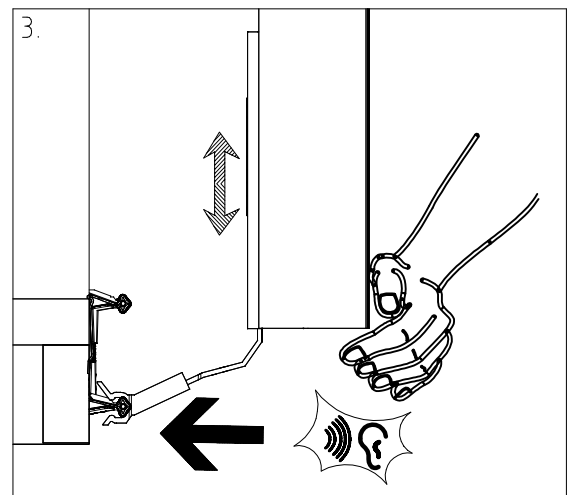
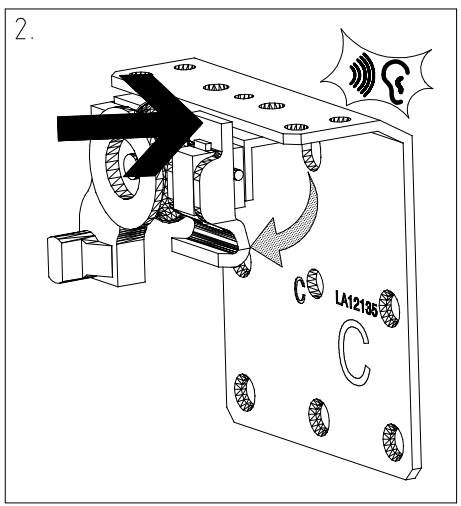
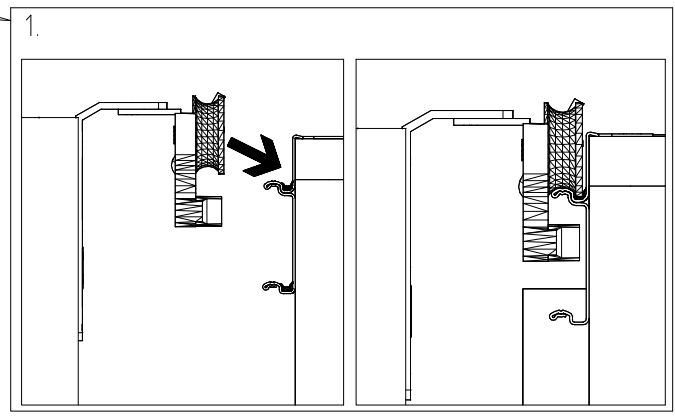
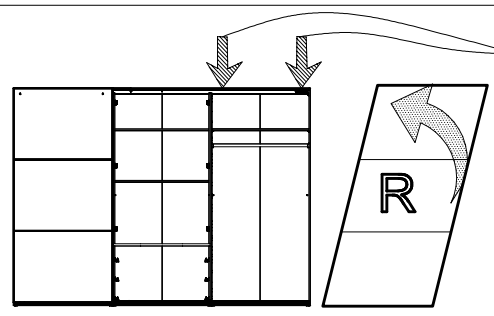
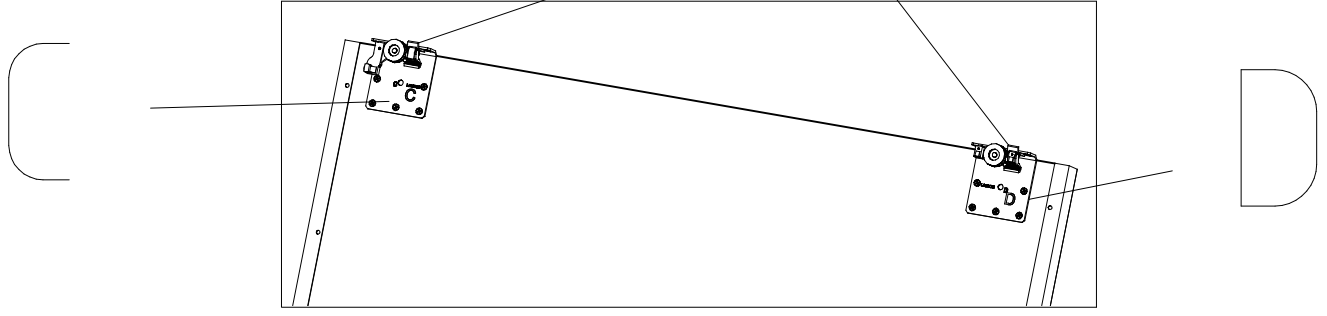
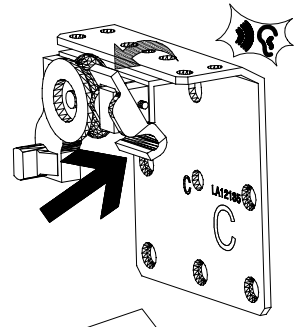
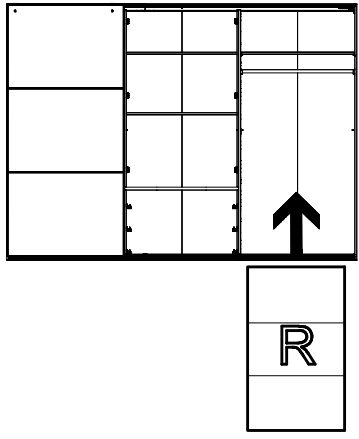

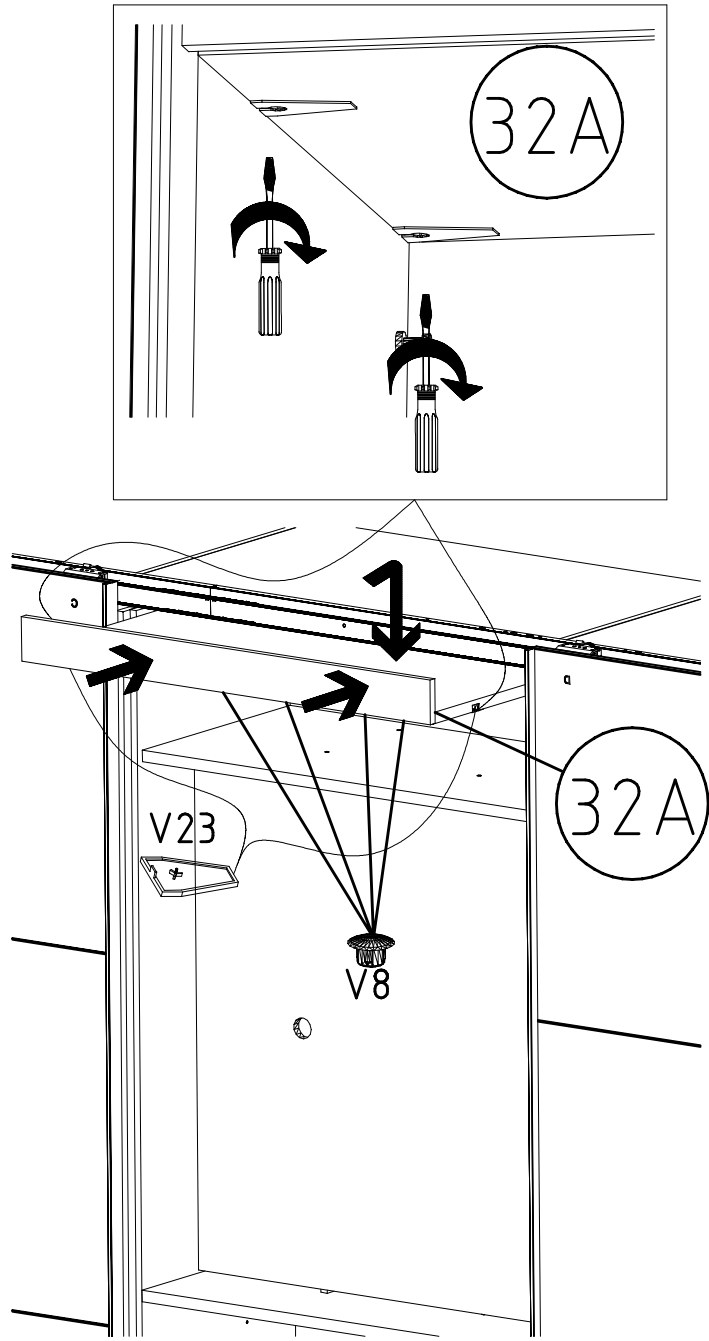



	V8		V23
111 xxx	Ø8	111 265	

50

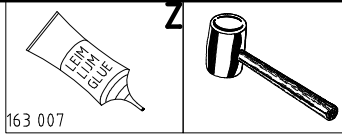

163 007

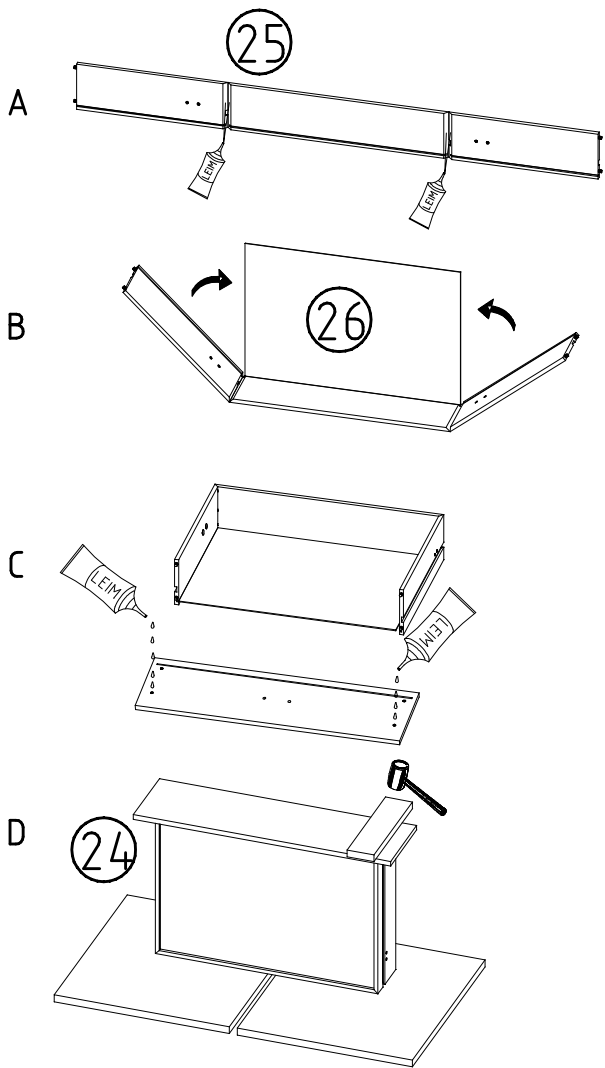

52

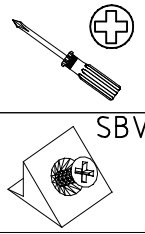

SBV

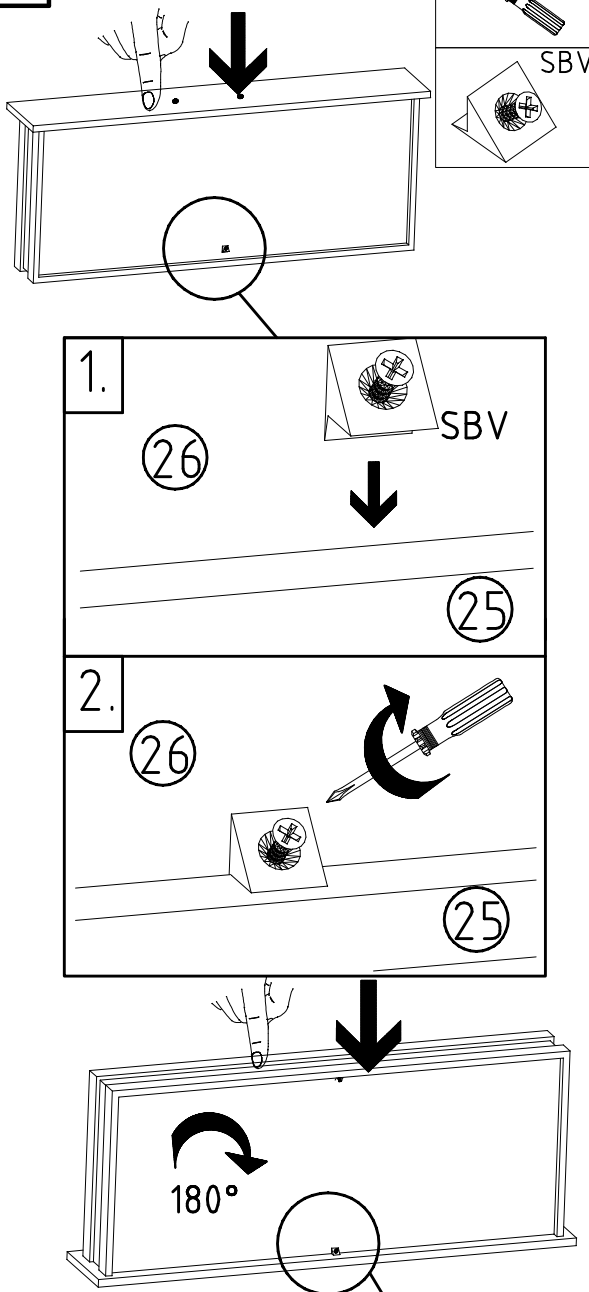

51

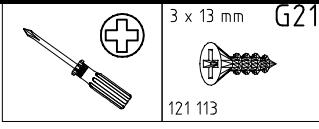

3 x 13 mm G21

121 113

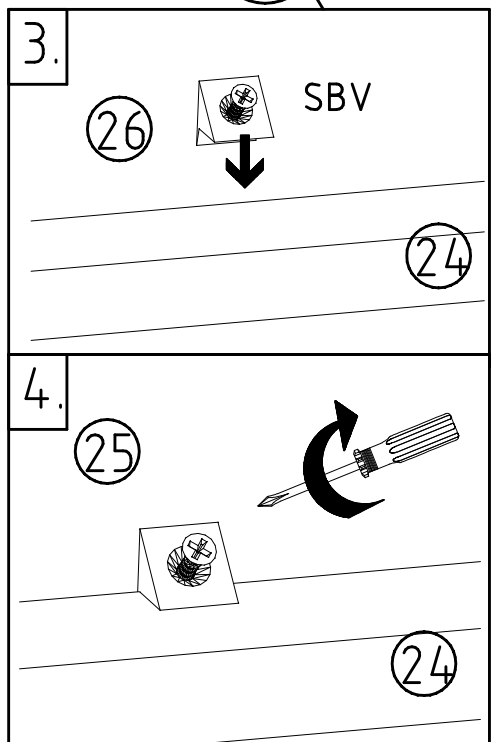
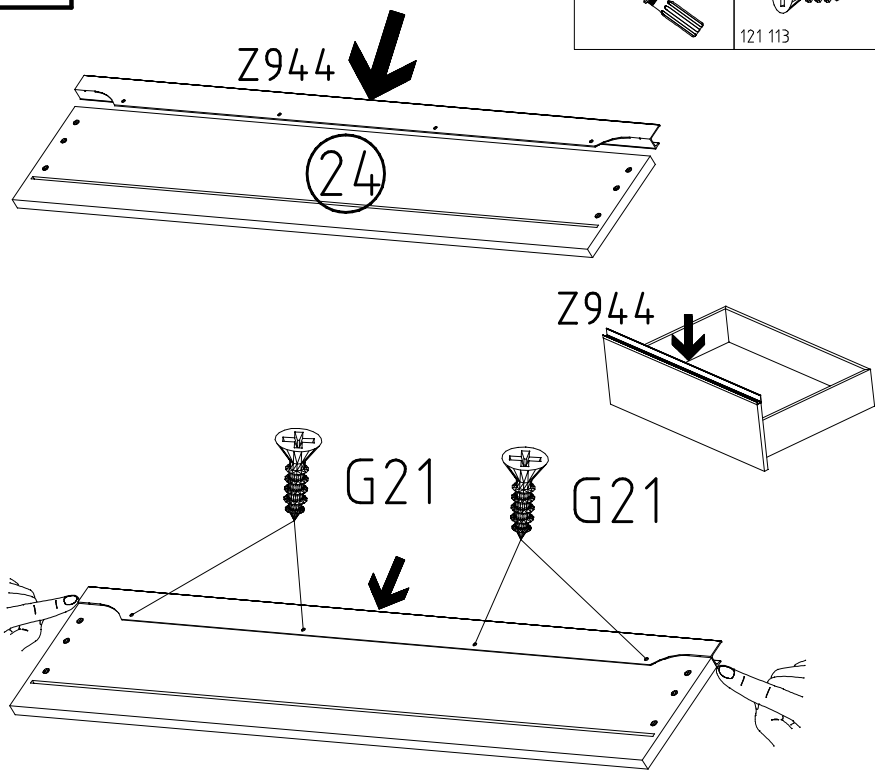

53

V40  
111 xxx

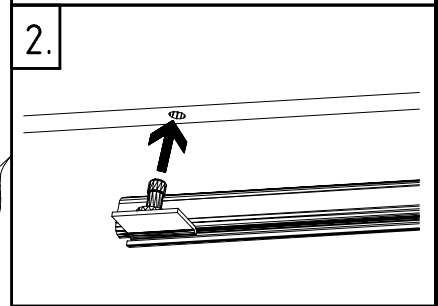
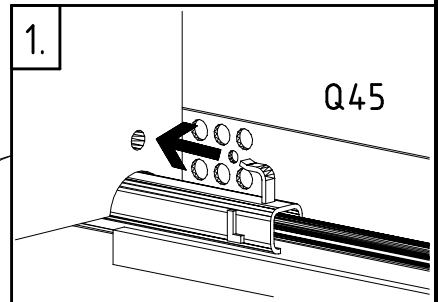
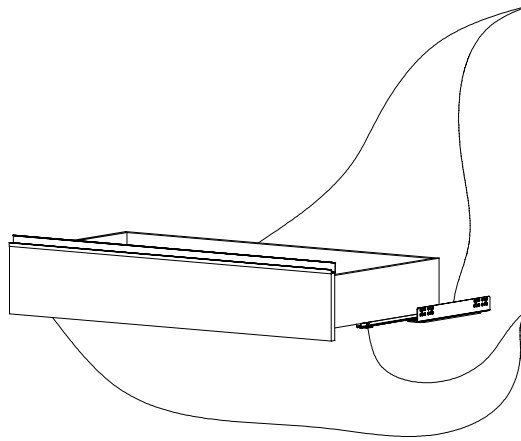
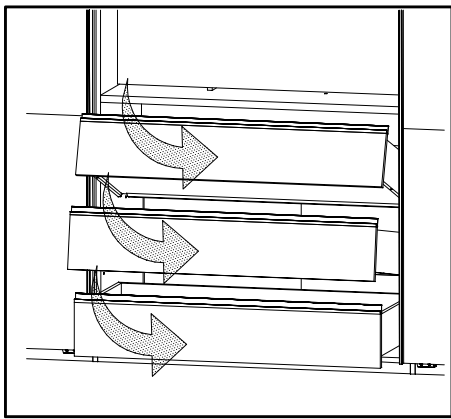
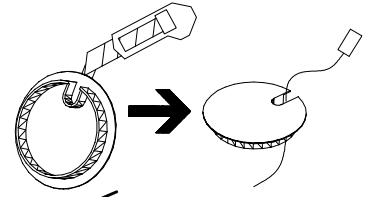
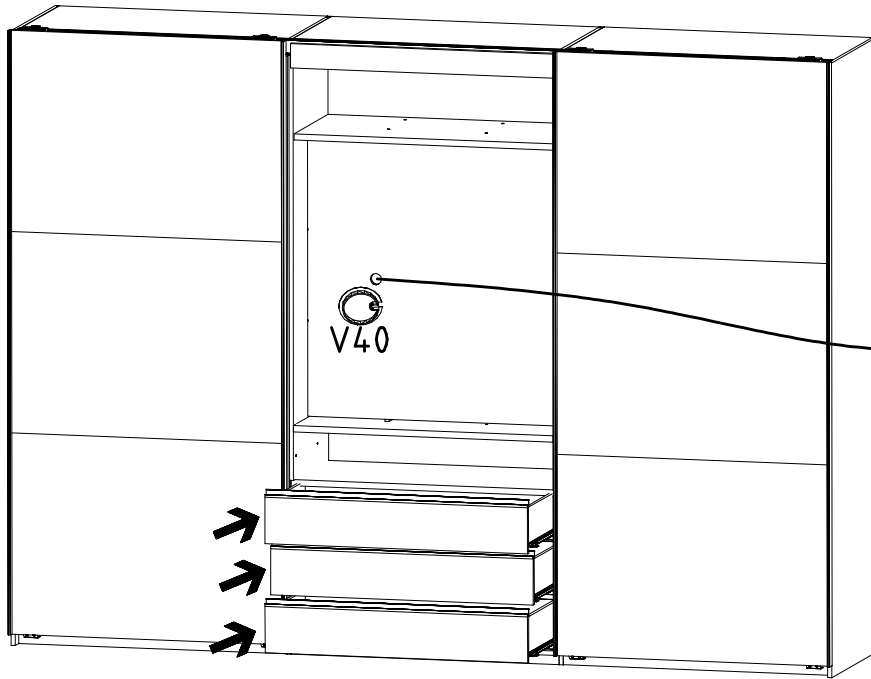

54

KP8  
352 302

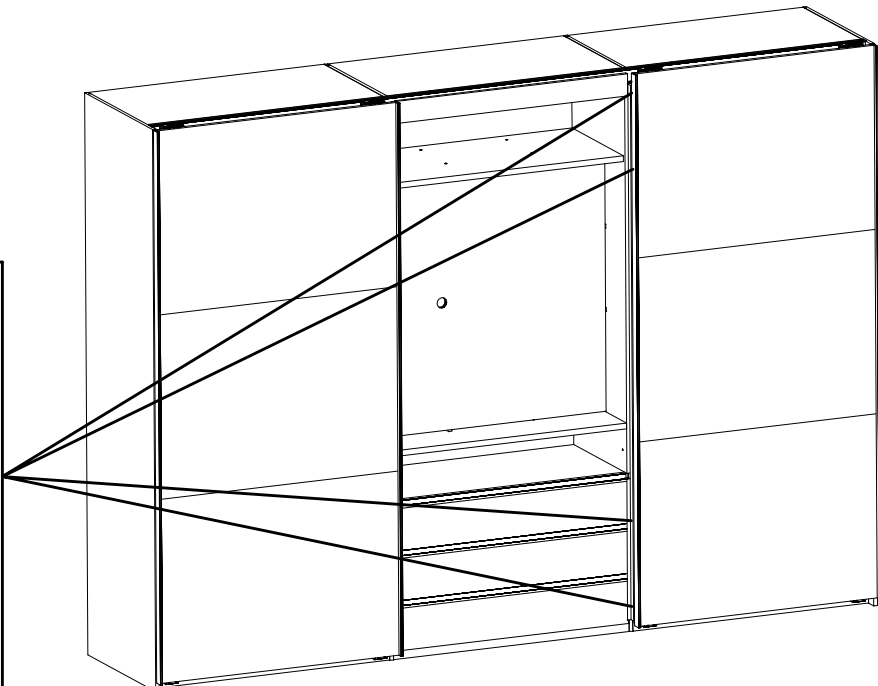
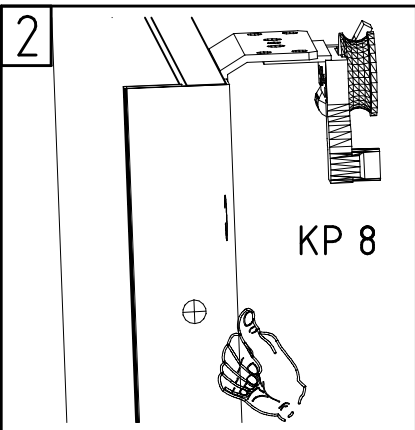
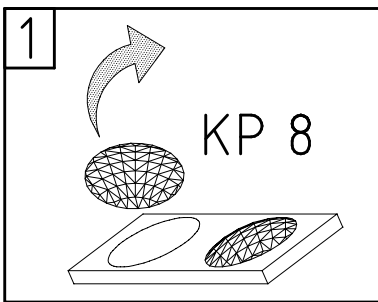

55

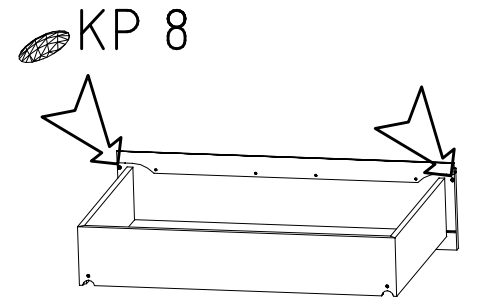
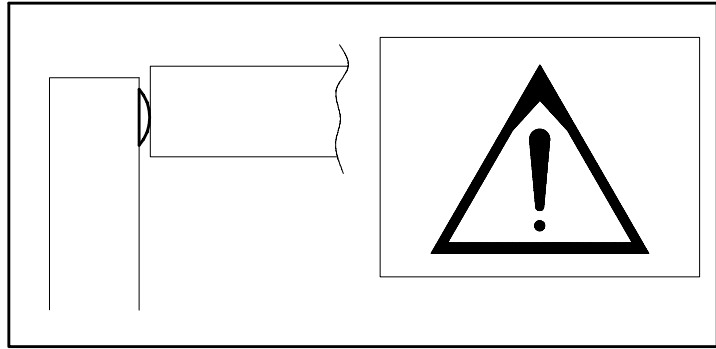
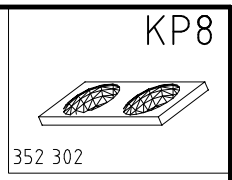
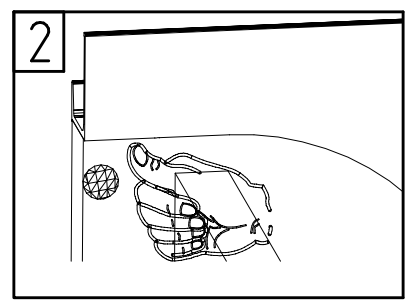
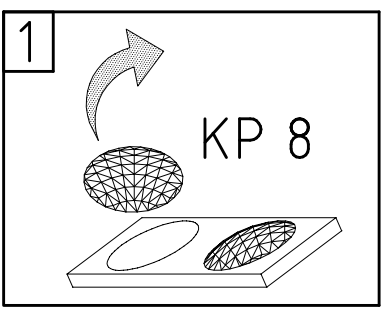

56

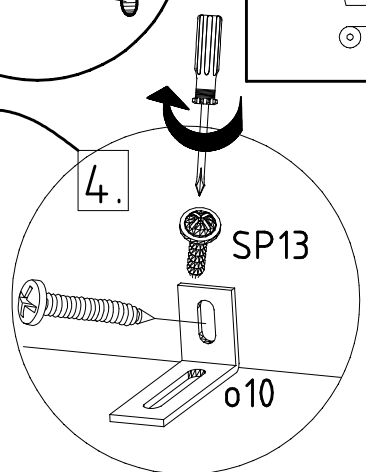
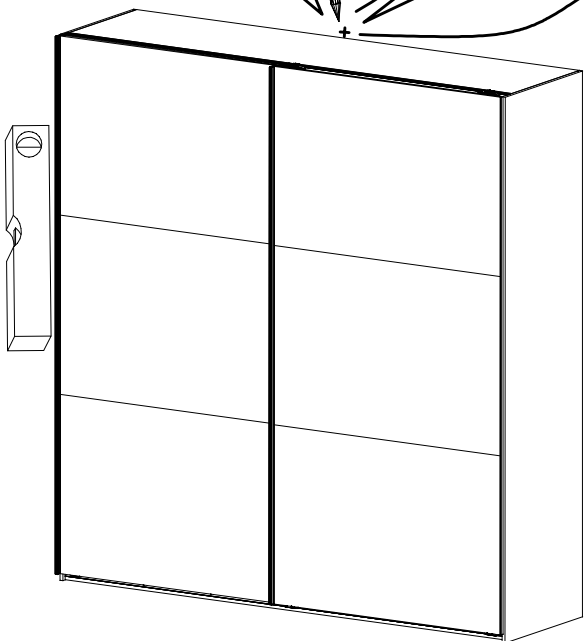
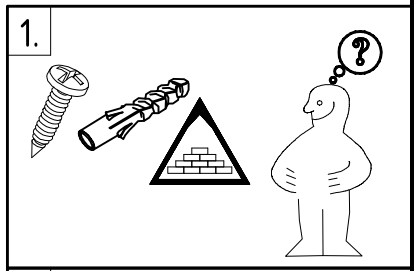
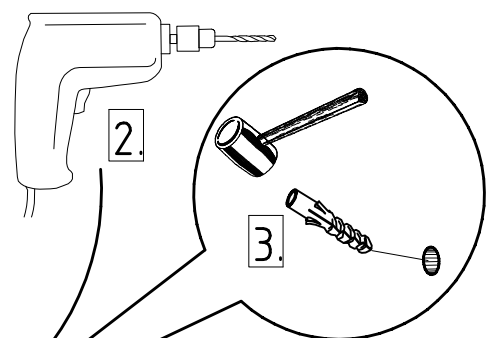
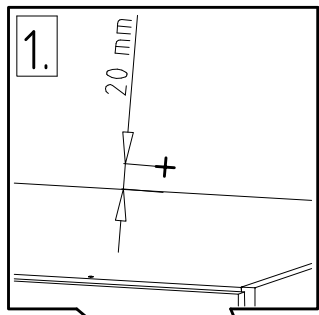
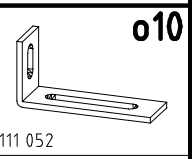
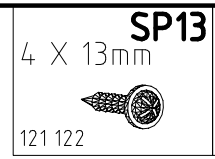
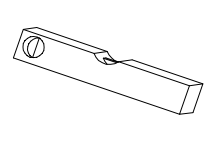
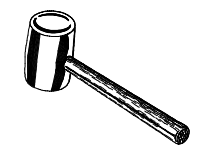
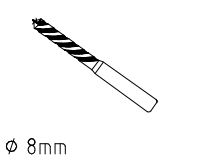
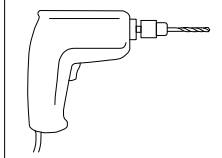

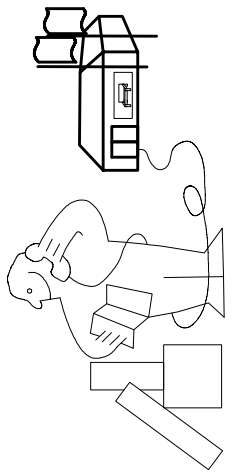
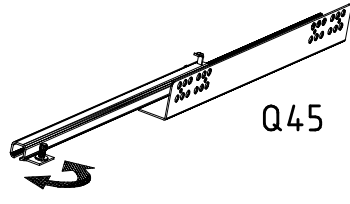
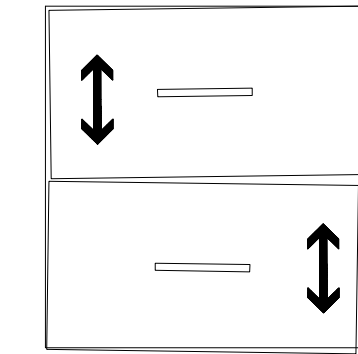
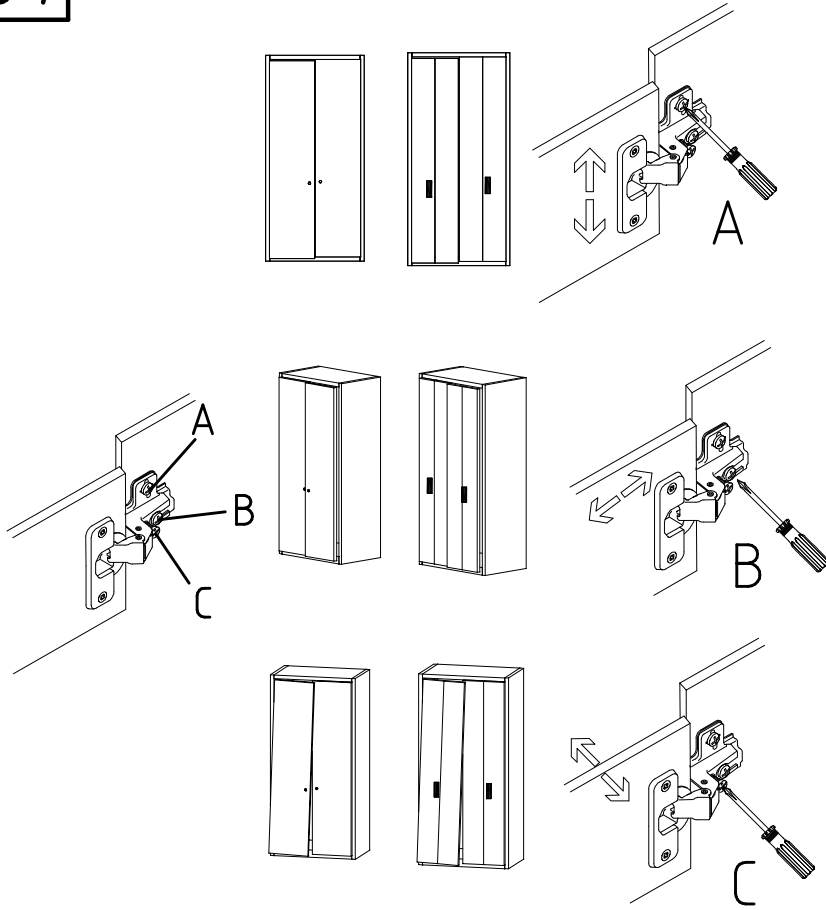

Modell/Modèle/Modèle

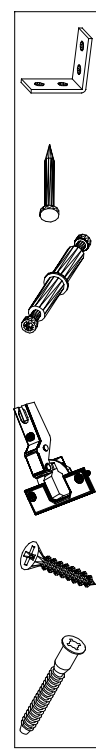
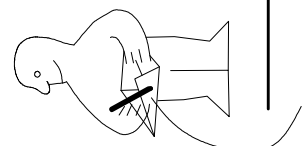
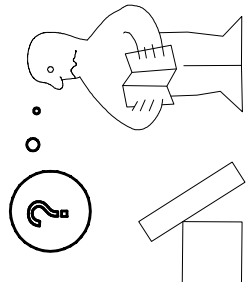
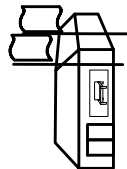
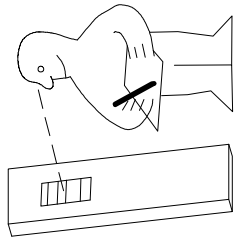

<121 370>	< G 1 >	<4x>

Änderungen die dem technischen Fortschritt geschuldet sind, behalten wir uns vor!  
 Bei nicht vorschriftsmäßiger und/ oder nicht fachmännischer Montage wird bei Personen- und/ oder Sachschäden keinerlei Haftung übernommen.