

MODELL: 57-515-75-3 ENERGY

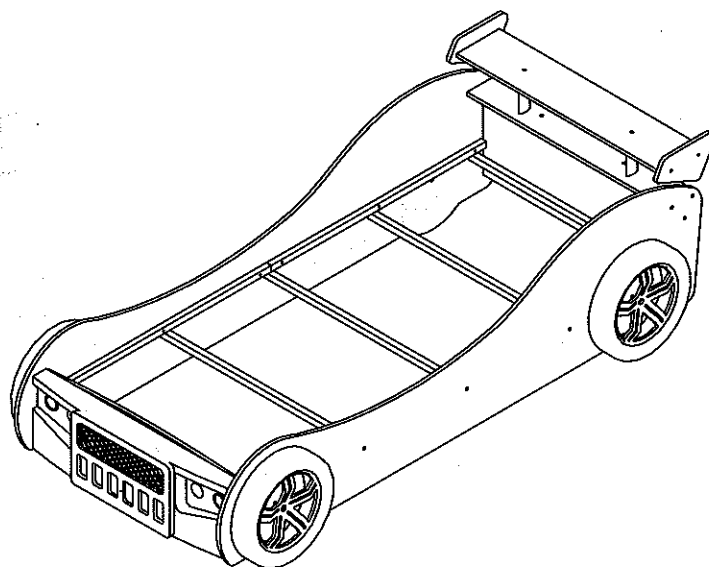

ASSEMBLE DIFFICULTY

1 2 ③ 4 5

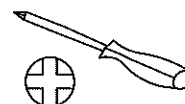

DESCRIPTION OF COMPONENT

ITEM NO	WORK PIECE DESCRIPTION	MEASUREMENT	QTY	COLOUR	SHAPE	PACK IN BOX
(1)	SIDE PANEL (L)	2150*600*15	1	RED		1/3
(2)	SIDE PANEL (R)	2150*600*15	1	RED		1/3
(3)	ARTICLE RIBS	1000*25*22	4	WHITE		1/3
(5)	BACK PANEL	905*354*15	1	RED		1/3
(6)	REAR UPPER MIDDLE FILTER	905*135*15	1	RED		1/3
(7)	REAR LOWER MIDDLE FILTER	905*135*15	1	RED		1/3
(8)	SQUARE PIPE	905*25*25	5	WHITE		1/3
(9)	REAR UPPER SIDE BOARD (L)	272*162*15	1	RED		1/3
(10)	REAR UPPER SIDE BOARD (R)	272*162*15	1	RED		1/3
(11)	CONNECTED IRON	150*60*20	2	BLACK		1/3
(12)	FRONT PANEL	905*300*15	1	RED		2/3
(16)	TYRE	410*410*72	4	BLACK		3/3
(18)	HARDWARE	216*114*57	1	BROWN		3/3

MODEL: B131R (905*2020)

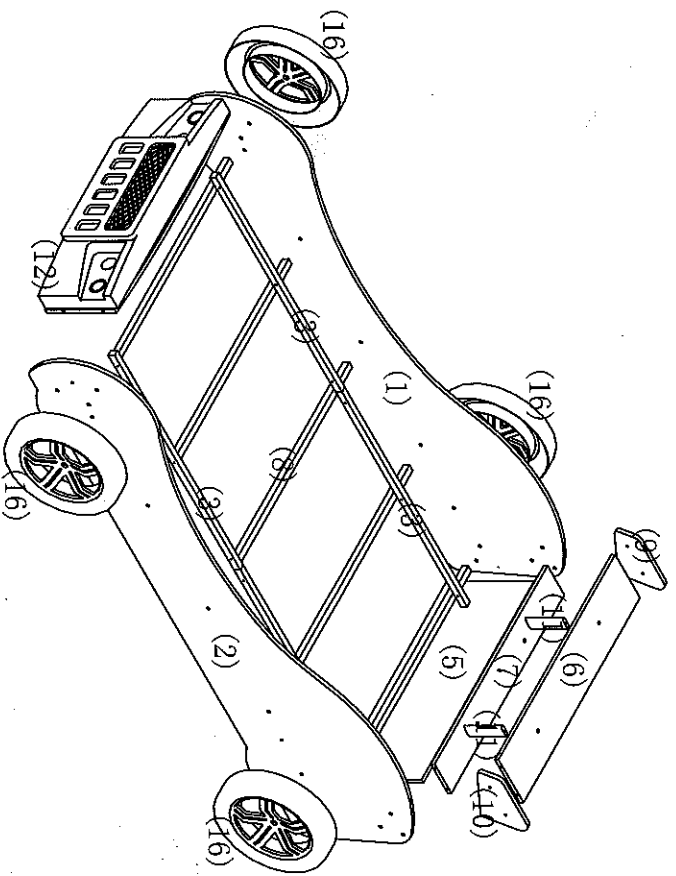

A	B	C	D	E	F	G
M6*55 QTY:4	M6*50 QTY:4	M8*25 QTY:12	M6*35 QTY:4			

1

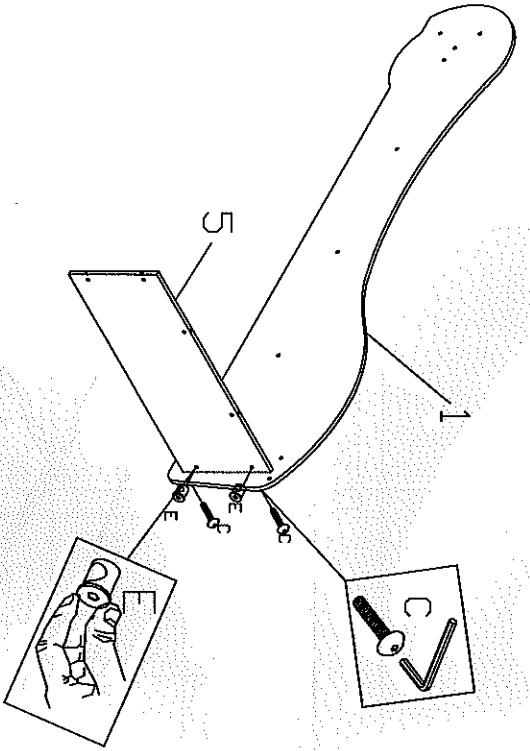

C M6*50 QTY:2

E

QTY:2

2

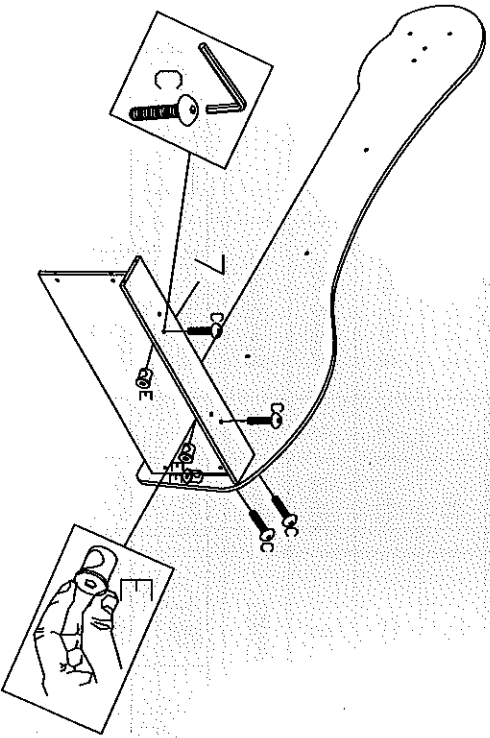

C M6*50 QTY:4

E

QTY:4

3

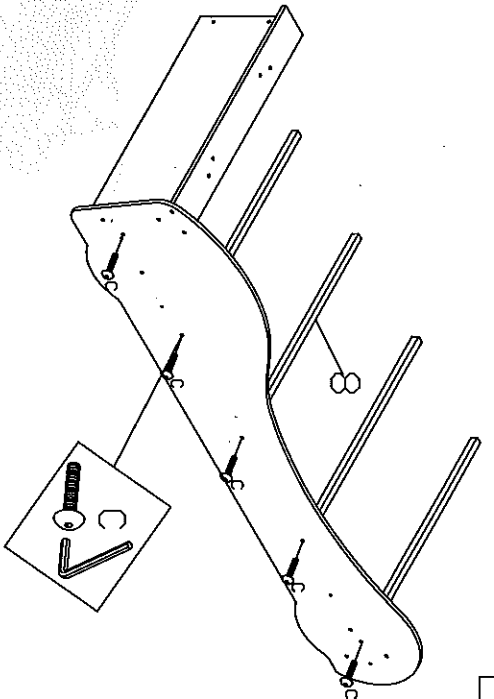

C M6*50 QTY:5

4

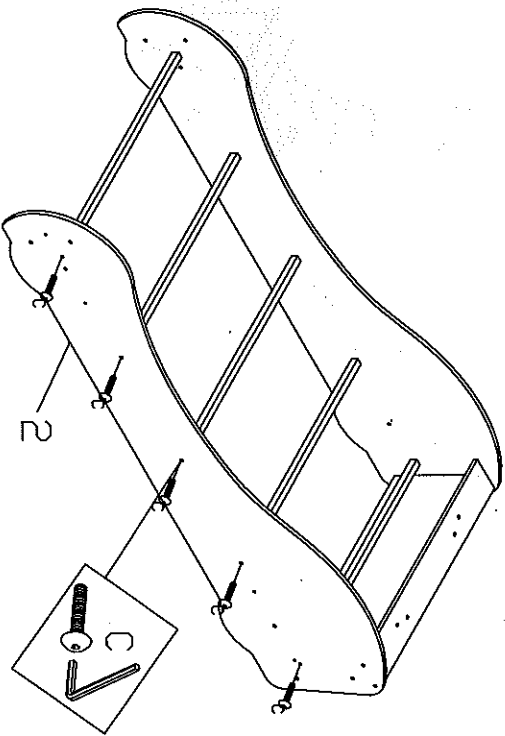

C M6*50 QTY:5

5

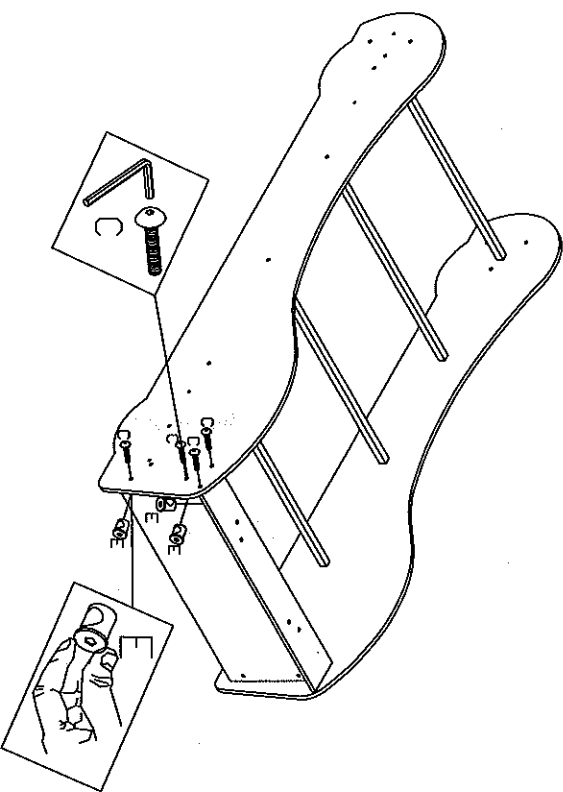

C M6*50 QTY:4
 E QTY:4

6

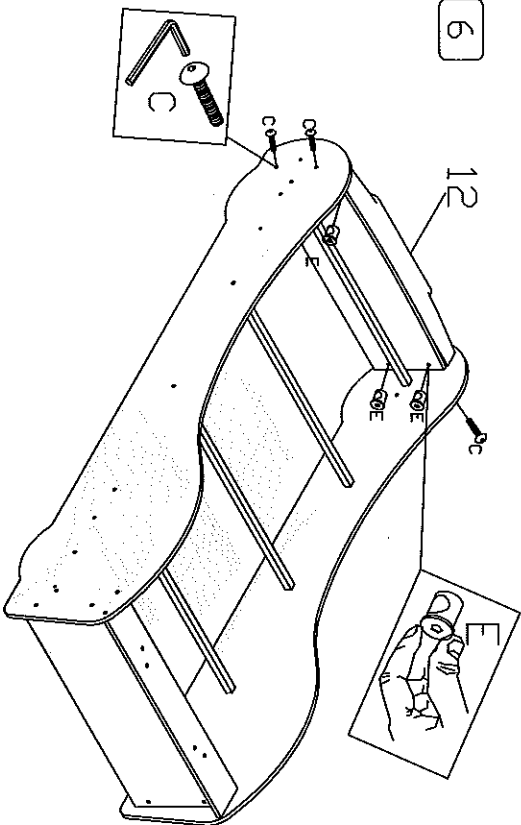

C M6*50 QTY:4
 E QTY:4

7

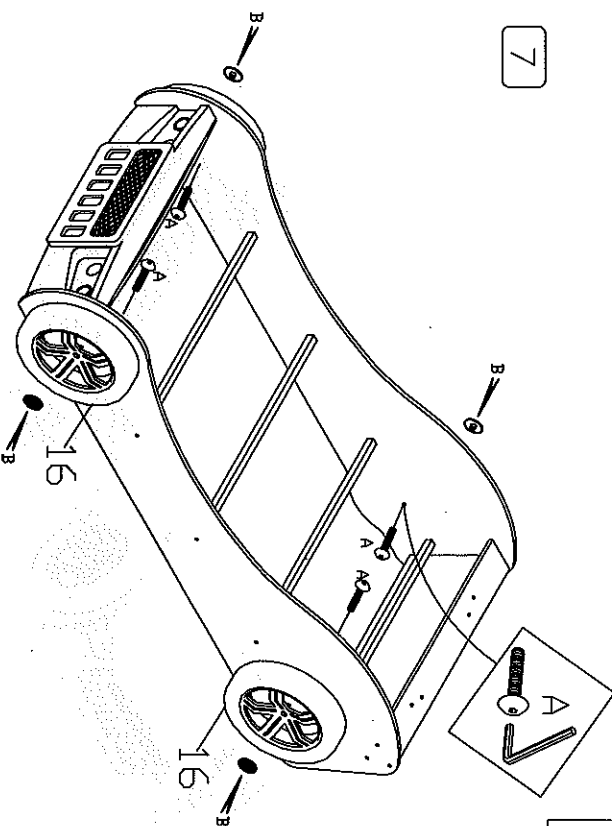

A M6*55 QTY:4
 B QTY:4

8

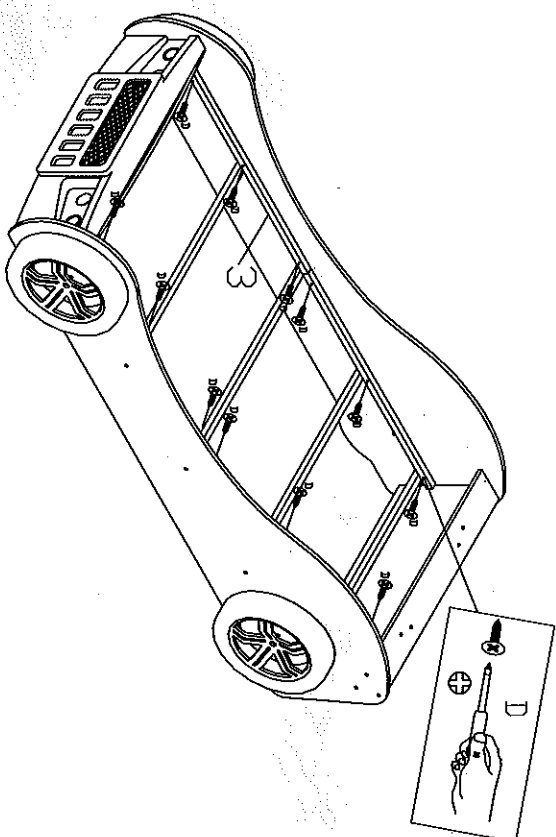

D M8*25 QTY:12

9

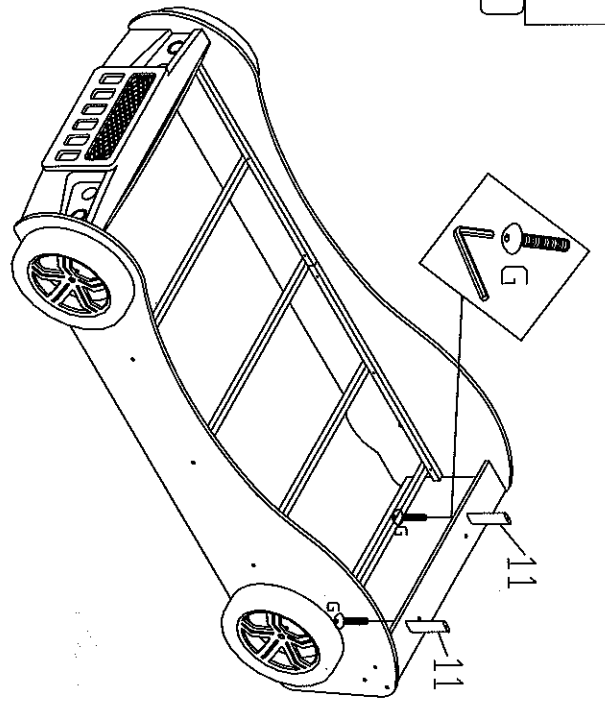

G
 M6*35
 QTY:2

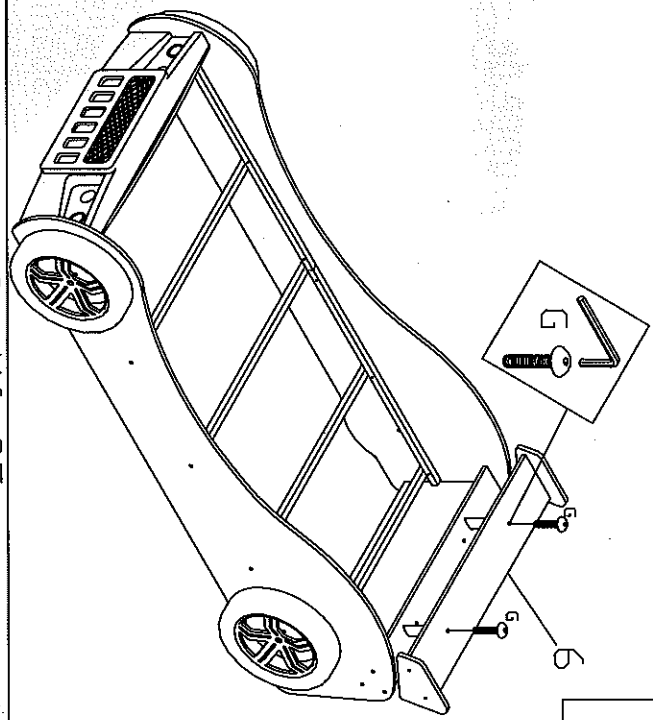

G
 M6*35
 QTY:2

10

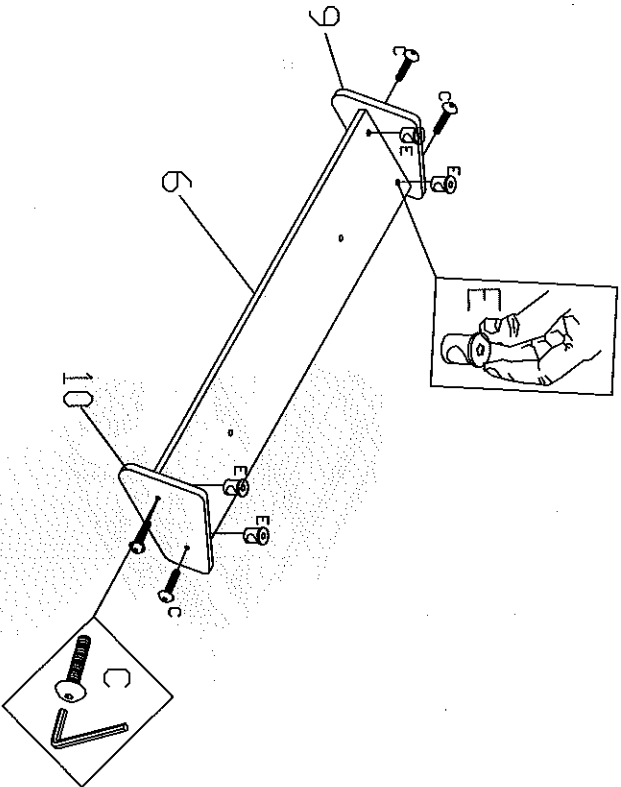

C
 M6*50
 QTY:4
 E
 QTY:4

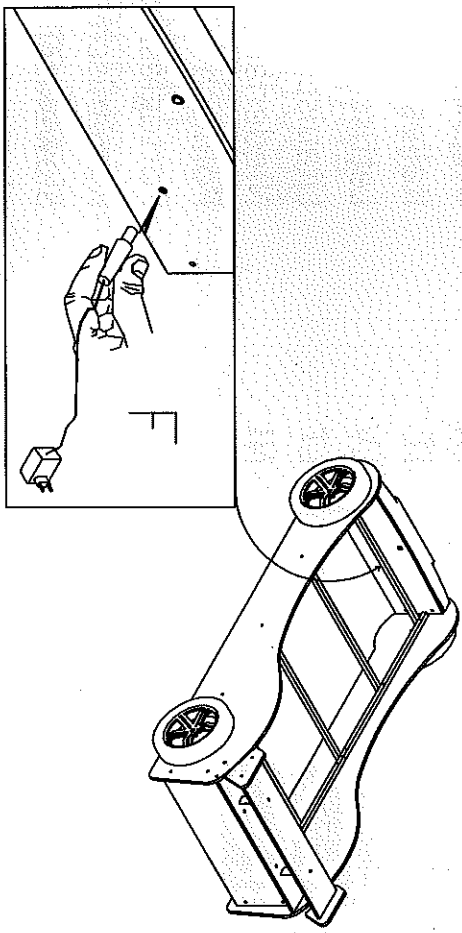

F

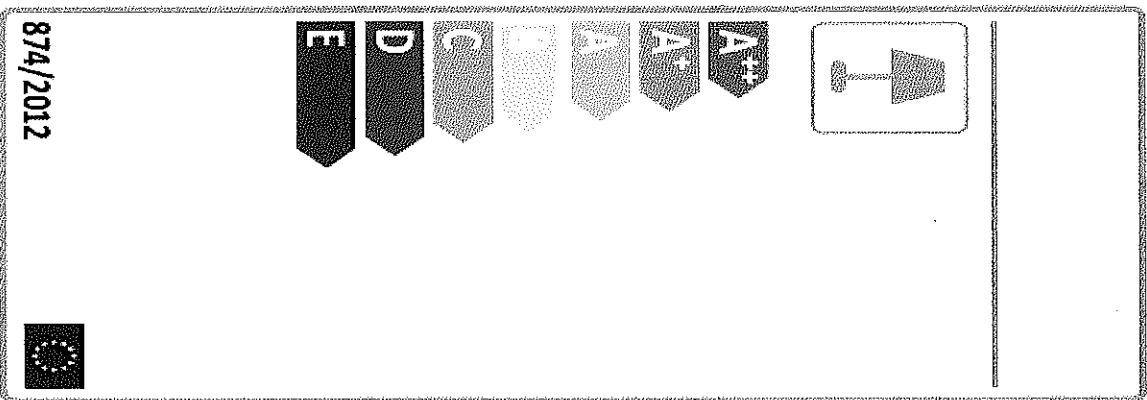

BG	Bulgarisch
CS	Tschechisch
DA	Dänisch
DE	Deutsch
ET	Estnisch
EL	Griechisch
EN	Englisch
ES	Spanisch
FR	Französisch
FI	Finnisch
HR	Kroatisch
HU	Ungarisch
IT	Italienisch
LV	Lettisch
LT	Litauisch
NL	Niederländisch
PL	Polnisch
PT	Portugiesisch
RO	Rumänisch
SK	Slowakisch
SL	Slowenisch
SV	Schwedisch

БЪЛГАРСКИ
 čeština
 Dansk
 Deutsch
 Eesti
 ελληνικά
 English
 español
 Français
 suomalaisainen
 hrvatski
 magyar
 Italiano
 Latvijas
 Lietuvos
 Nederlands
 Polski
 português
 român
 slovenský
 slovenščina
 Svenska

